



HEIDENHAIN



Position Display Units

Linear Encoders

for Manually Operated Machine Tools

September 2008

Digital readouts from HEIDENHAIN are used in a wide variety of applications. These include machine tools, infeed axes (e.g. on saws and presses), measuring and inspecting equipment, dividing apparatuses, setting tools, and measuring stations for production control. In order to meet the requirements of these applications, many encoders from HEIDENHAIN can be connected to the digital readouts.

The main application for digital readouts with two or more axes is on manually operated machine tools. Whether milling, drilling, boring or turning, the field-proven cycles provide the operator with optimal support. Digital readouts show the current position quickly and clearly, enabling a significant increase in work productivity. The most important linear encoders for position measurement on manually operated machine tools are also listed in this brochure.

You can find other encoders for connection to the display units on the Internet at www.heidenhain.de, or in the brochures entitled *Linear Encoders for Numerically Controlled Machine Tools*, *Length Gauges*, *Angle Encoders* and *Rotary Encoders*.



Contents

Position Display Units			
Overview	HEIDENHAIN Position Display Units		4
	Selection Guide		6
Functions	Metrological and Statistical Functions (ND 287)		8
	Probing Functions for Datums (ND 780, POSITIP)		10
	Tool Compensation (Series ND 500, ND 780, POSITIP)		11
	Distance-to-Go Display (Series ND 500, ND 780, POSITIP)		12
	Contour Monitoring (ND 500, POSITIP)		12
	Hole Patterns (Series ND 500, ND 780, POSITIP)		13
	Rectangular Pockets (POSITIP)		13
	Help When Working with Lathes (Series ND 500, ND 780, POSITIP)		14
	Programming of Machining Steps (POSITIP)		15
	Specifications	ND 200 Series – Universal Display Units for One Axis	
ND 500 Series – Straightforward Display Units for Two and Three Axes		18	
ND 780 – Adaptable Display Unit for up to Three Axes		20	
POSITIP 880 – The Programmable Display Unit for up to Six Axes		22	
Mounting			24
Electrical Connection	Encoders		28
	Interfaces	Overview	30
		Encoders	31
		Analog Input	32
		Serial Data Transfer	32
		Switching I/O	34
	Cable Overview		40
Linear Encoders for Manually Operated Machine Tools			
Overview			42
Mounting Information			44
Specifications	LS 300 Series		46
	LS 600 Series		48
Electrical Connection	Interfaces	Incremental Signals \sim 1 V _{PP}	50
		Incremental Signals \square TTL	52
	Connecting Elements and Cables		54

HEIDENHAIN Position Display Units

– Designed for the Real World

HEIDENHAIN digital readouts have universal application: In addition to standard tasks on milling, drilling and boring machines and lathes, they also offer ideal solutions for many applications on machine tools, measuring and testing equipment, and special machines—in fact all machines where axis slides are moved manually.



Versatile, ergonomic, and well thought-out

Digital readouts from HEIDENHAIN are designed for user friendliness.

Typical characteristics:

- Highly readable graphic display
- Graphic support and help functions
- Conversational user guidance
- Simple, logically arranged keypad helps you quickly master the available functions and enter positions reliably and rapidly
- Ergonomically designed push-button keypad with symbols that withstand years of use
- Splash-protected front panel prevents damage to the display unit from coolant
- Sturdy cast-metal housing built for the worst of day-to-day workshop conditions



– Operational Advantages

Fast

HEIDENHAIN position displays save you time. The distance-to-go display feature allows you to approach the next nominal position quickly and reliably, simply by traversing to a display value of zero. Datums can be set wherever needed. This simplifies positioning, especially for workpieces with complicated dimensions.

When milling or boring hole patterns or rectangular pockets, you can enter the geometric data simply and quickly. The positions are approached directly using the distance-to-go display.

On lathes, the sum display feature for saddle and top slide contributes to more accurate positioning. If taper dimensions are not complete, the display unit will help you to calculate the angles.

The POSITIP is ideal for small-batch production, because repetitive machining sequences can be stored as programs and then used as often as required.

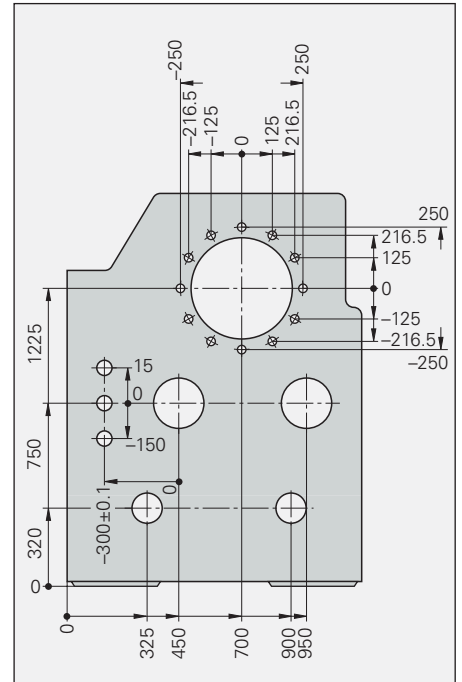

Reliable

A highly readable display shows the measured positions with respect to the selected datum. As a result, the probability of error is reduced and machining becomes more reliable.

The graphic positioning aid of the POSITIP, ND 780 and ND 52x improves the speed and reliability of the distance-to-go display. Graphic illustrations help you to enter the geometric data correctly.

Accurate

On older machine tools, precise machining in the range of 0.01 mm is a matter of luck, since worn machine elements make exact dial and vernier settings impossible.

Linear encoders from HEIDENHAIN sense machine slide movement directly. The backlash caused by mechanical transfer elements such as lead screws, racks and gears therefore has no influence. By determining the slide position directly, you achieve higher machining accuracy and reduce scrap rates.



Selection Guide

ND 200 Series

Position and measured value displays for measuring devices, adjustment and testing equipment, automated tasks, as well as simple infeed and positioning tasks with **one axis**

- Monochrome (ND 280) or color screen (ND 287)
- Splash-proof full-travel keyboard
- Switching inputs/outputs (ND 287)

Number of axes	Datums	Functions
1	2	–
		<ul style="list-style-type: none"> • Distance-to-go display • Metrological and statistical functions (sorting, measurement series, SPC) • Offsetting a second encoder (optional) for sum/difference display, temperature compensation

ND 500 Series

Digital readout for milling, drilling and boring machines, as well as lathes, with **two or three axes**

- Monochrome screen
- Membrane keyboard

Number of axes	Datums/ Tool data	Functions
2	10 datums, 16 tools	<p><i>General:</i></p> <ul style="list-style-type: none"> • Distance-to-go display with graphic positioning aid • Contour monitoring <p><i>Milling and drilling</i></p> <ul style="list-style-type: none"> • Hole patterns (circular and linear patterns) • Tool compensation <p><i>Turning:</i></p> <ul style="list-style-type: none"> • Radius/diameter display • Separate and sum display
3		

ND 780

Digital readout for milling, drilling and boring machines, as well as lathes, with **up to three axes**

- Monochrome screen
- Splash-proof full-travel keyboard
- Switching inputs/outputs (via IOB 49)

Number of axes	Datums/ Tool data	Functions
Up to 3	10 datums, 16 tools	<p><i>General:</i></p> <ul style="list-style-type: none"> • Distance-to-go display with graphic positioning aid <p><i>Milling and drilling</i></p> <ul style="list-style-type: none"> • Hole patterns (circular and linear patterns) • Tool compensation • Probing functions for datums <p><i>Turning:</i></p> <ul style="list-style-type: none"> • Radius/diameter display • Separate and sum display • Constant surface speed (via IOB 49)

POSITIP 880

Digital readout for milling, drilling and boring machines with **up to six axes**, and for lathes

- Color screen
- Program memory
- Splash-proof full-travel keyboard
- Switching inputs/outputs (via IOB 89)

Number of axes	Datums/ Tool data	Functions
Up to 6	<p><i>Milling and drilling</i></p> 99 datums, 99 tools	<p><i>General:</i></p> <ul style="list-style-type: none"> • Distance-to-go display with graphic positioning aid • Contour monitoring • Programming of machining steps <p><i>Milling and drilling</i></p> <ul style="list-style-type: none"> • Hole patterns (circular and linear patterns) • Tool compensation • Probing functions for datums • Roughing out rectangular pockets <p><i>Turning:</i></p> <ul style="list-style-type: none"> • Radius/diameter display • Separate and sum display • Turning with allowances • Multipass cycle
	<p><i>Turning:</i></p> 1 datum; 99 tools	

Encoder inputs	Switching I/O	Data interface	Model	Page
\sim 1 V _{PP} \sim 11 μ A _{PP} EnDat 2.2	–	RS-232-C/V.24 USB	ND 280	16
	Yes	RS-232-C/V.24 USB Ethernet (option)	ND 287	



Encoder inputs	Switching I/O	Data interface	Model	Page
\square TTL	–	USB	ND 522	18
			ND 523	



Encoder inputs	Switching I/O	Data interface	Model	Page
\sim 1 V _{PP} \sim 11 μ A _{PP}	<ul style="list-style-type: none"> • For KT edge finder • For edge finder with contact triggering • Additional via IOB 49 	RS-232-C/V.24	ND 780	20



Encoder inputs	Switching I/O	Data interface	Model	Page
\sim 1 V _{PP} \sim 11 μ A _{PP} EnDat 2.1	<ul style="list-style-type: none"> • For KT edge finder • Additional via IOB 89 	RS-232-C/V.24, Centronics	PT 880	22



Functions

– Metrological and Statistical Functions (ND 287)

Sorting and tolerance checking

With the sorting function, workpieces can be inspected for dimensional accuracy and divided into classes. To do so, the ND 287 compares the displayed measured value with an upper and lower limit value previously entered with the keypad. The result (whether the measured value is below, above or within tolerance) is indicated in color in the status display as a value or with one of the symbols <, = or >. In addition, a corresponding signal is available at the switching outputs.

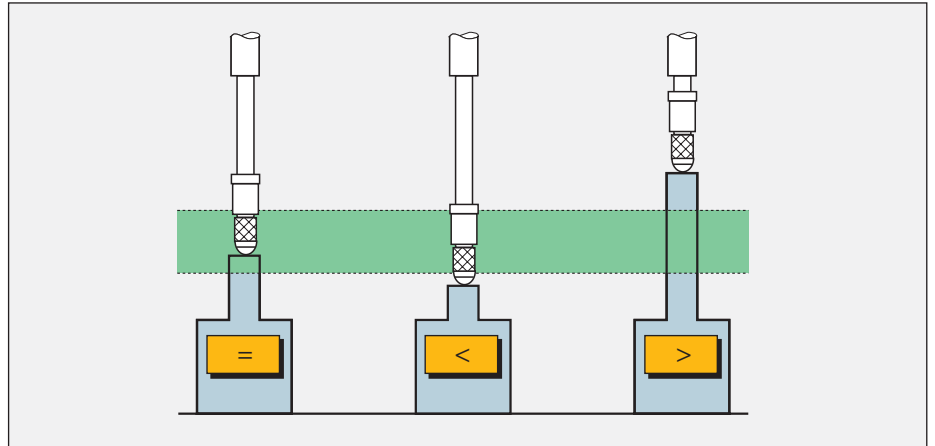

Workpiece sorting

Combination with a second encoder

A second encoder can be connected to the ND 287 through the optional encoder input assembly **encoder module** or **analog module**. The data from two encoders can be combined through mathematical operands. Like the two measured values, the result is saved in the measured value memory. This opens further areas of application:

Sum/Difference Display

The ND 287 uses the two measured values to calculate the sum, the difference, or according to an entered formula, and displays the result. Both measured values can also be displayed individually.



"Within tolerance"

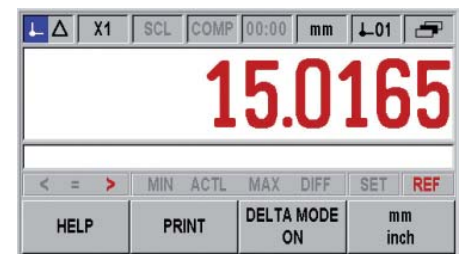

"Out of tolerance"

Temperature compensation

An analog temperature sensor detects the temperature of the measured object. On the basis of the entered temperature coefficients, the ND 287 calculates the compensated length value of the measured object.

Display freeze

To be able to read the display reliably in spite of quickly changing values you can send an external signal to hold the display. The true position value is counted internally. While the display is frozen, the unit is updated with every signal to the new measured value and the frozen/concurrent display is frozen only for the duration of the external signal.

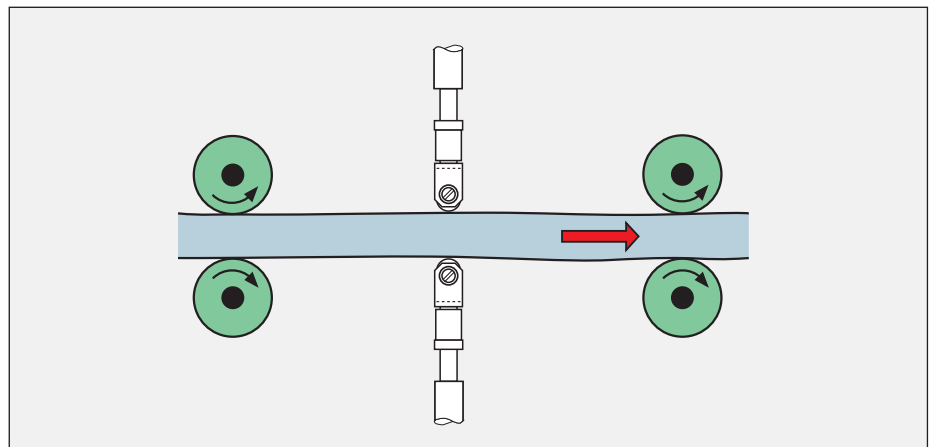

Sum of two length gauges

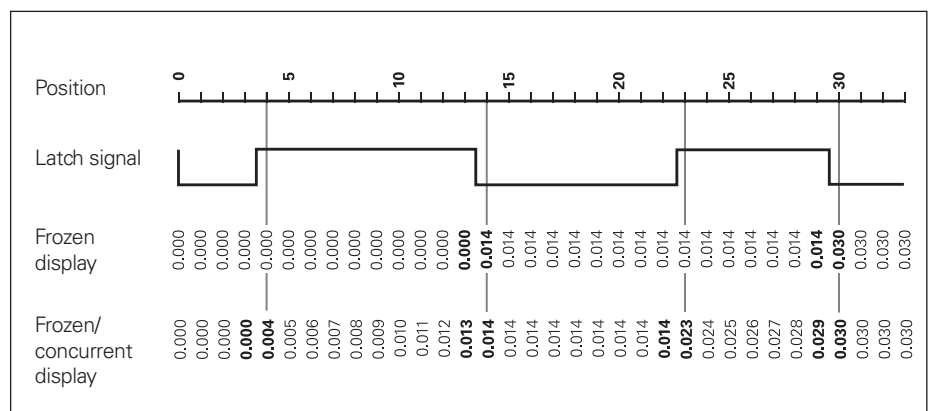

Function of the display freeze features

Measurement series

The ND 287 can store measurement series with up to 10 000 measured values. The measured values are written by keystroke, over an external command, or cyclically by an internal clock (≥ 20 ms; adjustable). They can be evaluated internally or they can be read out in a block. While the measurement series is running, the display can show the minimum value, maximum value, or the difference of the two instead of the current measured value. In addition, the displayed value can be checked with the classification function for compliance to tolerances.

The stored measured values can be shown and evaluated in different ways.

- **Statistical view** with arithmetic mean, standard deviation and range
- **Diagram** with graphical display of all measured values, minimum/maximum and mean values, and tolerance limits (with activated sorting function).
- **Measured value overview** with tabular view of the measured values.

Statistical process control (SPC):

The ND 287 features functions for statistical process control. Before beginning measurements, the **number** of samples and the measured values per sample are defined and the nominal dimension, **tolerance limits** and **control limits** are entered. The measured value logging for SPC is started manually or externally. It can be started, continued or deleted. The ND 287 saves up to 1000 measured values in a nonvolatile FIFO memory.

To evaluate the recorded measured values, the ND 287 provides the following functions:

- **Statistical view** of measured values in the FIFO memory
- **Measured value overview** with tabular view of the measured values.
- **Diagram** with graphical display of the last 30 measured values
- **Histogram** in ten classes with **Probability density function** and **process capability indexes** c_p and c_{pk}
- Control chart for **mean \bar{x} standard deviation s** and **range r** (difference of largest and smallest value) of a sample

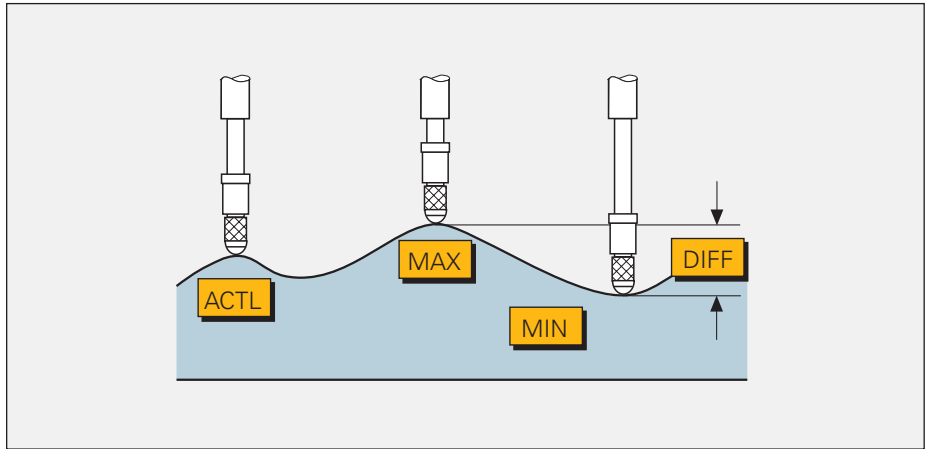

Minimum/maximum value storage

ANALYSIS MEASUREMENT SERIES		X1
Number of measured values :		3000
Maximum value [MAX] :		20.0840
Minimum value [MIN] :		17.4815
Difference [MAX - MIN] :		2.6025
Average value :		19.0605
Standard deviation :		± 0.6480
EXPORT	GRAPH	MEASURED VALUES
		HELP

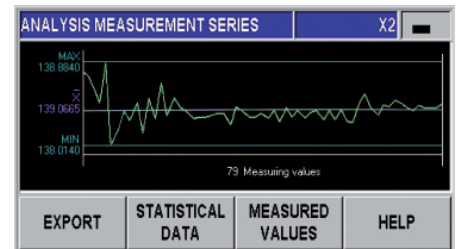

SPC ANALYSIS		X1
Number of measured values :		51
Maximum value [MAX] :		9.3775
Minimum value [MIN] :		1.1600
Difference [MAX - MIN] :		8.2175
Average value :		4.1982
Standard deviation :		± 1.7601
CHART	MEASURED VALUES	EXPORT
		HELP

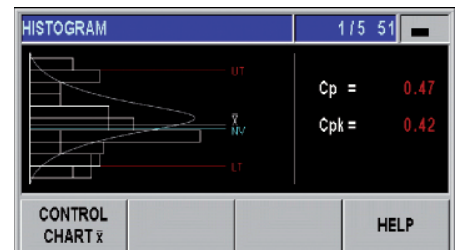

LIST OF MEASURED VALUES FOR SPC				1 / 5 51
Measured values : 25 - 48				Page 2 of 3
4.0975	3.5890	3.4560	3.5810	
3.9240	3.7310	6.5650	9.3775	
3.2530	4.2625	3.4600	5.0410	
3.6220	7.6510	6.0740	5.5755	
4.3270	5.7295	4.7655	6.7265	
5.9170	5.1355	4.5255	6.9460	
SPC ANALYSIS		EXPORT		HELP



Functions

– Probing Functions for Datums (ND 780, POSITIP)

Easy setup with probing functions

A very valuable accessory for datum setting is the HEIDENHAIN KT edge finder. Simply move the edge finder toward a side of the workpiece until the stylus deflects. The counter automatically stores the exact position, taking into account the direction of approach and the radius of the stylus. In milling machine mode, the ND 780 and POSITIP digital readouts offer the following probe functions:

- Workpiece edge as reference line
- Workpiece centerline as reference line
- Circle center as datum

For electrically conductive workpieces, these functions are also possible on the ND 780 with an edge finder with contact triggering to ground.

Datum setting with the tool

The probe functions can also be carried out with the tool.

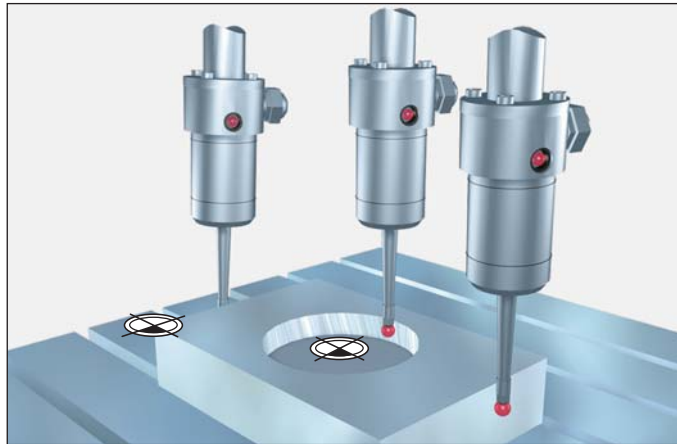

Accessory: KT edge finder

The KT is a triggering edge finder. The cylindrical stylus is spring-mounted in the edge finder housing. The stylus is deflected when it contacts the workpiece, and the edge finder sends a triggering signal over the connecting cable to the ND or the POSITIP.

The KT edge finder allows you to set datums quickly and easily, without leaving marks on the workpiece.

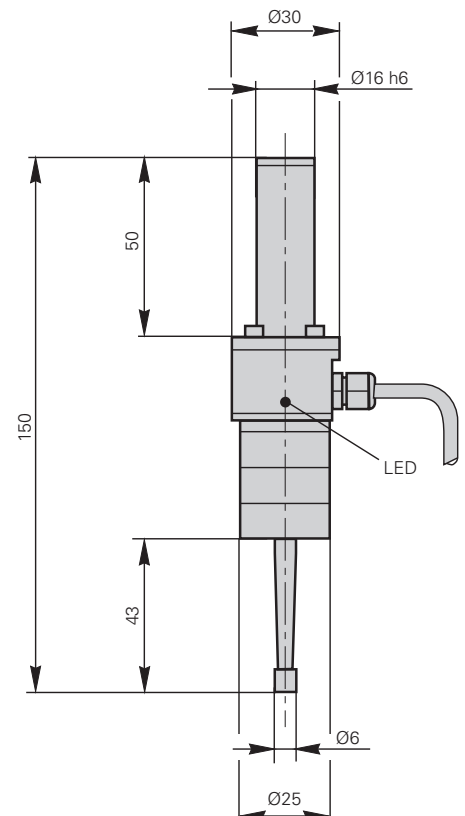

– Tool Compensation (Series ND 500, ND 780, POSITIP)

Tool compensation for milling machines

The digital readouts of the ND 500, ND 780 and POSITIP series can save tool data, i.e. diameter, and the POSITIP also saves the length and axis of the tool in use. The POSITIP 880 features a tool table for 99 tools, in which the data of pre-set tools or tool data determined on the machine can be stored.

When positioning in distance-to-go mode, the readouts take the tool radius (R+ or R-) in the machining plane into account, and the POSITIP also considers the tool length (ΔL) in the spindle axis.

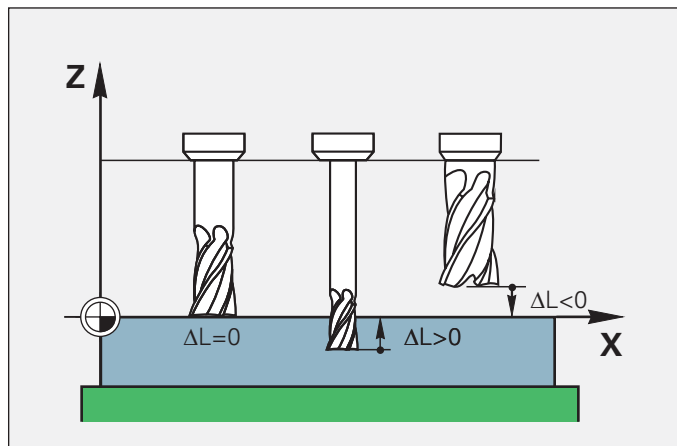
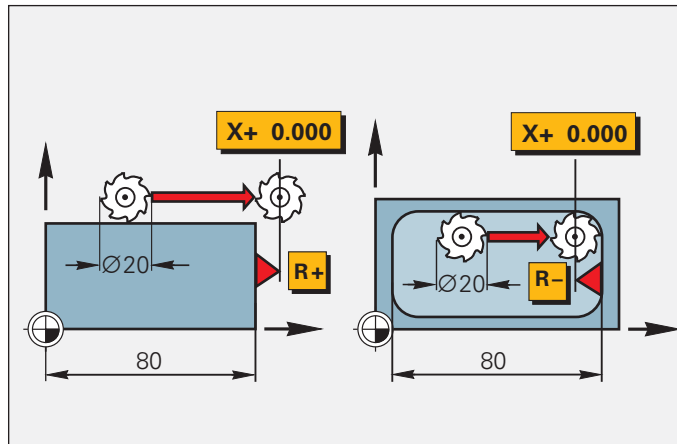

Determining and storing tool compensation values on lathes

With the ND 52x or ND 780 (16 tools) and the POSITIP (99 tools) readouts, you can store the dimensional data for the tools you insert in the turret or quick-change holder:

- Enter the tool position directly when turning the first diameter, or
- “freeze” the current axis position value, retract the tool, measure the turned diameter and then enter that value.

Changing datums

If you change the workpiece or the workpiece datum, you can fix the new datum without having to change the stored tool-offset values. The tool data are automatically referenced to the new datum.

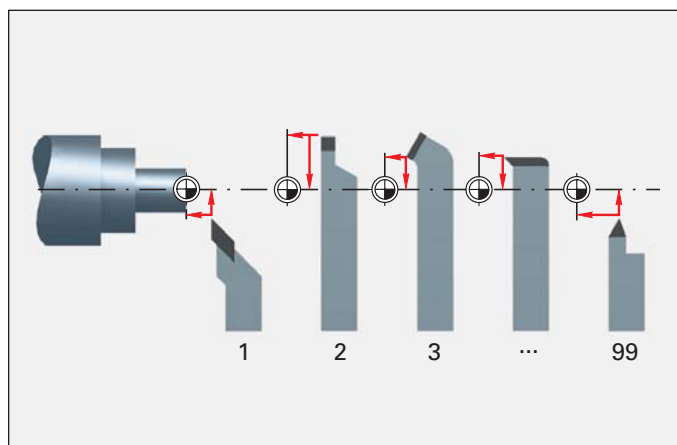

Functions

- Distance-to-Go Display (Series ND 200, ND 500, ND 780, POSITIP)
- Contour Monitoring (ND 500 Series, POSITIP)

Distance-to-go display for turning and milling

The distance-to-go display feature simplifies your work considerably: you enter the next nominal position, and the display shows you the distance remaining to the target position. This means you simply traverse to the display value zero.

The displays for milling can also compensate the cutter radius. This way you can directly use the drawing dimensions without having to do any conversions. You no longer have to remember any complicated values.

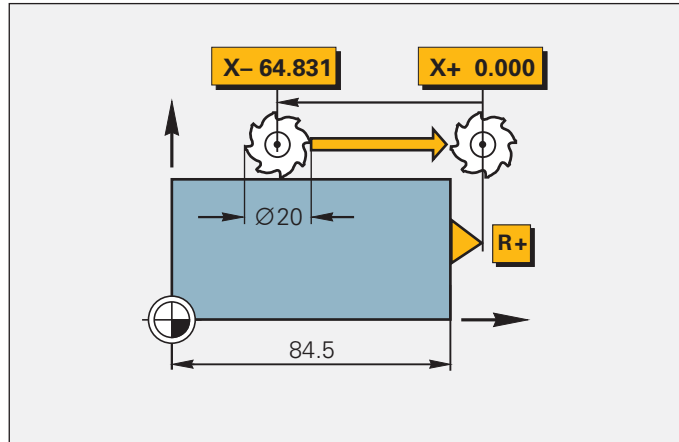

On POSITIP, the distance-to-go display is enhanced by a graphic positioning aid: As you traverse to zero, a square cursor moves into a target fork. If you prefer (for example for turning), the display can show the absolute position value instead of the graphic.

POSITIP's distance-to-go display
With the POSITIP, you can turn while compensating for **oversizes**. Simply enter the oversize and use the distance-to-go display to traverse to zero.

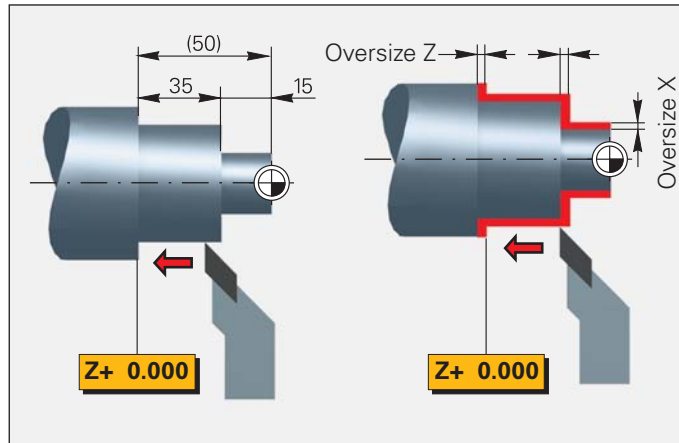

ND 500 series, POSITIP: Contour monitoring for overseeing manual 2-D operations

Particularly for 2-D milling and turning, the contour monitoring function shows you whether you are moving the tool near to the defined contour. The POSITIP supports it in an especially compatible way: it shows whether you are still within the tolerance limits that you have defined. The magnify function makes this possible even for relatively narrow tolerances while a second window provides you with an overall view of the workpiece.

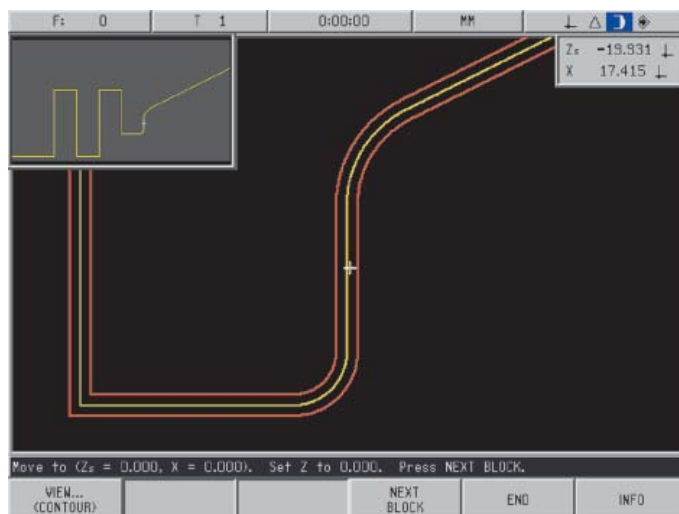

- Hole Patterns (Series ND 500, ND 780, POSITIP)
- Rectangular Pockets (POSITIP)

Automatic calculation of bolt hole patterns for milling and drilling

In milling machine mode you can machine **bolt hole circles** (full circle or circle segments) and **linear hole patterns** without having to calculate:

You simply enter the geometric dimensions and the number of holes from the drawing. The display calculates the coordinates of the individual holes in the working plane. You only need to traverse "to zero" and drill. Then the display shows the next position. The **graphic display** is a particularly useful feature: it lets you verify your input of the programmed bolt-hole pattern before machining.

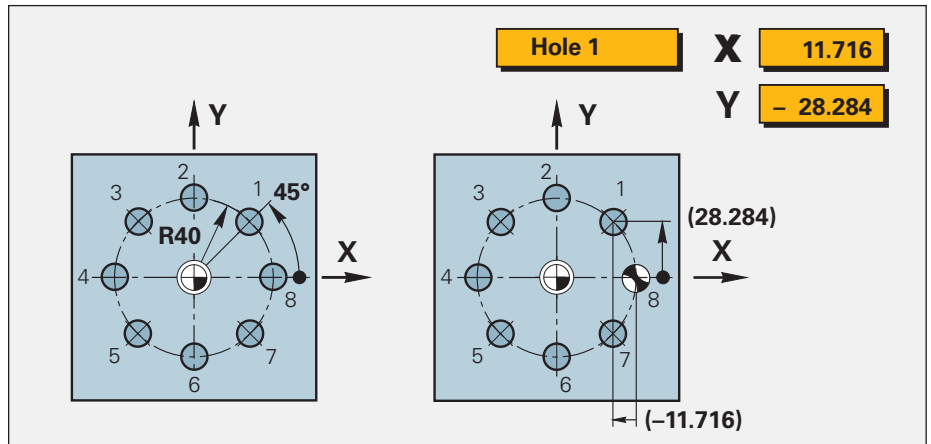

D:0 | T:1 | F: 0 | 0:00 | MM |

LINEAR PATTERN		Select the pattern type (ARRAY or FRAME).
TYPE	ARRAY	
FIRST HOLE		
X	20.000	
Y	15.000	
HOLES PER ROW	4	
ARRAY FRAME		HELP

3 3 F: 0 T2: 4.0000 H# DRILL / 2 0:00:00 H# L

SINGLE CYCLE

001	CYL. 1.0 (R40)
002	CYL. 1.2 (CX +0.000000)
003	CYL. 1.3 (CY +0.000000)
004	CYL. 1.4 (HP +0.000000)
005	CYL. 1.5 (START 27.05.00)
006	CYL. 1.6 (DEPTH 7.00)
007	CYL. 1.6 (DEPTH 7.00)

HOLE 1 OF 8 Move to (X = 0.000, Y = 0.000). Drill Z to 7.00. Press NEXT HOLE.

VIEW: (OPEN/GRAPH) PREVIOUS HOLE NEXT HOLE END



Milling and roughing out rectangular pockets

POSITIP helps you to rough and mill rectangular pockets. The display unit calculates from your input the required positioning steps, and you simply traverse to the zero position value.

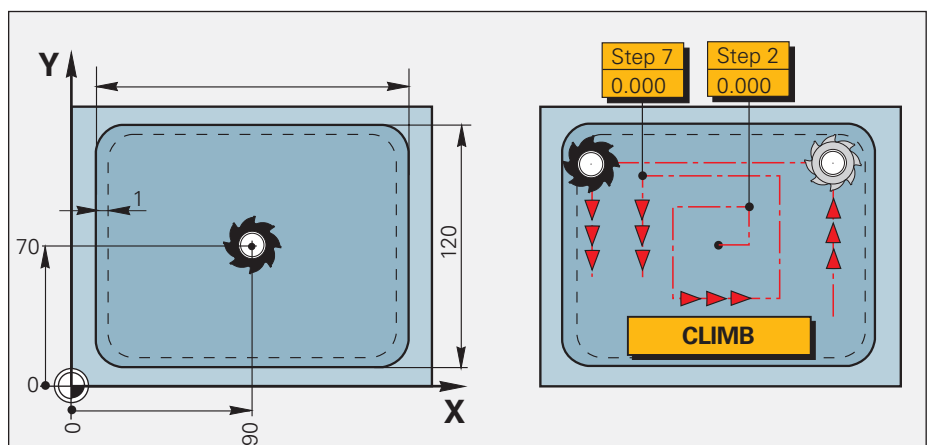

Functions

– Features for Working with Lathes (Series ND 500, ND 780, POSITIP)

Radius/diameter display

In the lathe mode you can see the positions of the transverse axis in either radius or diameter values. You can switch at a keystroke.

Sum display of longitudinal axes

In lathe mode, the positions of the saddle and the top slide are displayed either separately or as the sum of both values.

- If you select **separate displays**, the position values are referenced to the datum for each individual axis. If only the saddle is moved, the displayed value for the top-slide axis remains unchanged.
- If **sum display** is selected, the counter adds both values. You can now read the absolute position of the tool in relation to the workpiece datum—without having to calculate!

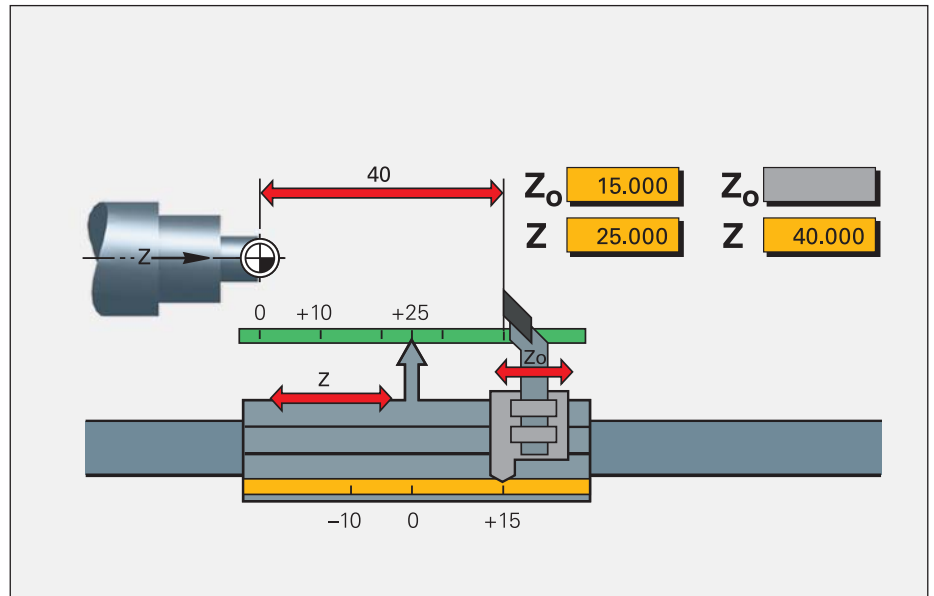

Taper turning made easy

If taper dimensions do not include the angle, the integrated taper calculator will help you with the calculation. Simply enter the taper ratio or the two diameters and the length. The correct angle for the top slide will be displayed immediately.

Multipass cycle

The POSITIP display unit features a cycle for turning a shoulder in several passes. The distance remaining to the target position is shown both in the longitudinal and tool axes. You decide on the best infeed increment.

Constant surface speed

Particularly in taper turning or parting, the surface speed usually changes along with the diameter. But a constant surface speed is better for optimum machining results and long tool life. The ND 780 position display unit in conjunction with the output module IOB 49 therefore makes it possible to control workpiece rotation to ensure a constant surface cutting speed in spite of a changing workpiece diameter.

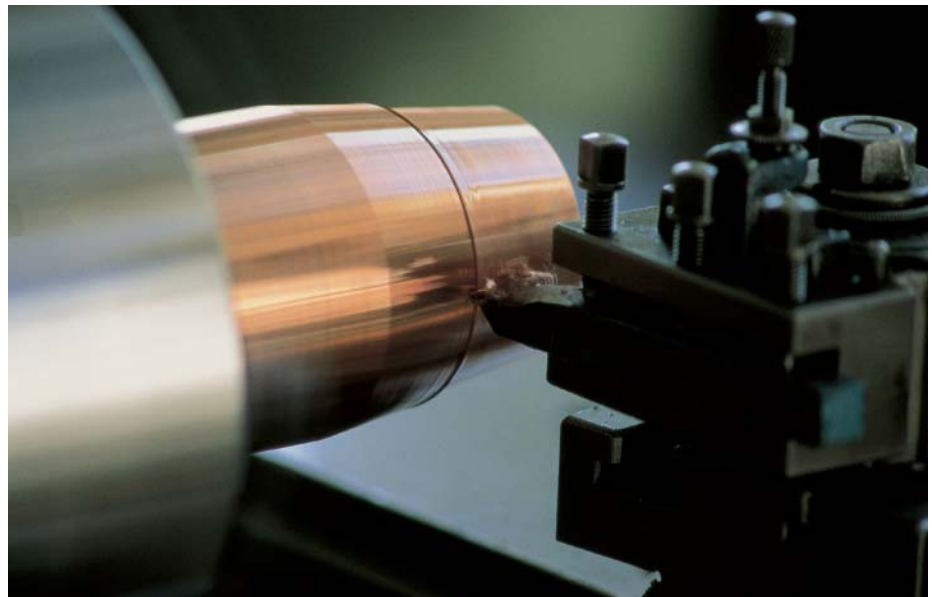

– Programming of Machining Steps (POSITIP)

POSITIP's programming functions allow you to save repetitive machining steps as a program. Thus, for example, you can save all of the machining sequences required for a small-batch workpiece as a program. In the Programming mode of operation, the distance-to-go display will guide you step-by-step to the programmed positions.

You can create programs by either keying them in step by step or generating them through actual position capture (teach-in programming).

POSITIP also allows you to generate program-section repeats and subprograms. If you are machining point patterns, you can program incremental positioning steps and then repeat them as often as necessary (program-section repeat). If you need to run the same program sequence at separate locations on the workpiece, you can write a subprogram and call it as needed. This saves you work at the keyboard and reduces inputting errors. Fixed cycles such as Bolt Hole Circle, Linear Hole Pattern or Rectangular Pocket (boring, milling) or Multipass (turning) keep your programs short and save you programming time. In the course of your work, POSITIP presents each nominal position in the proper sequence. You need only move from one position to the next.

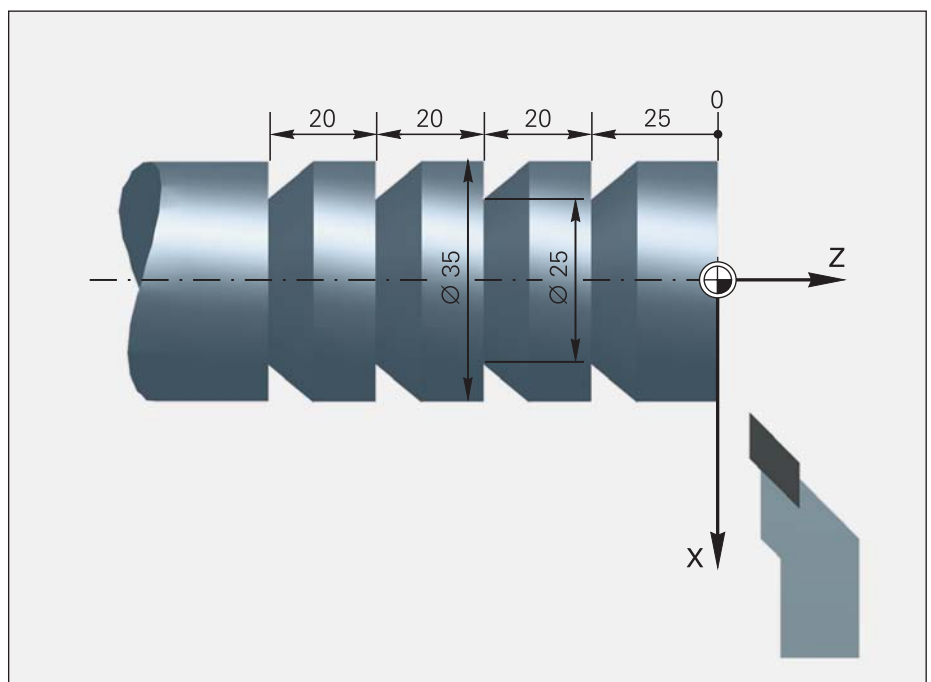
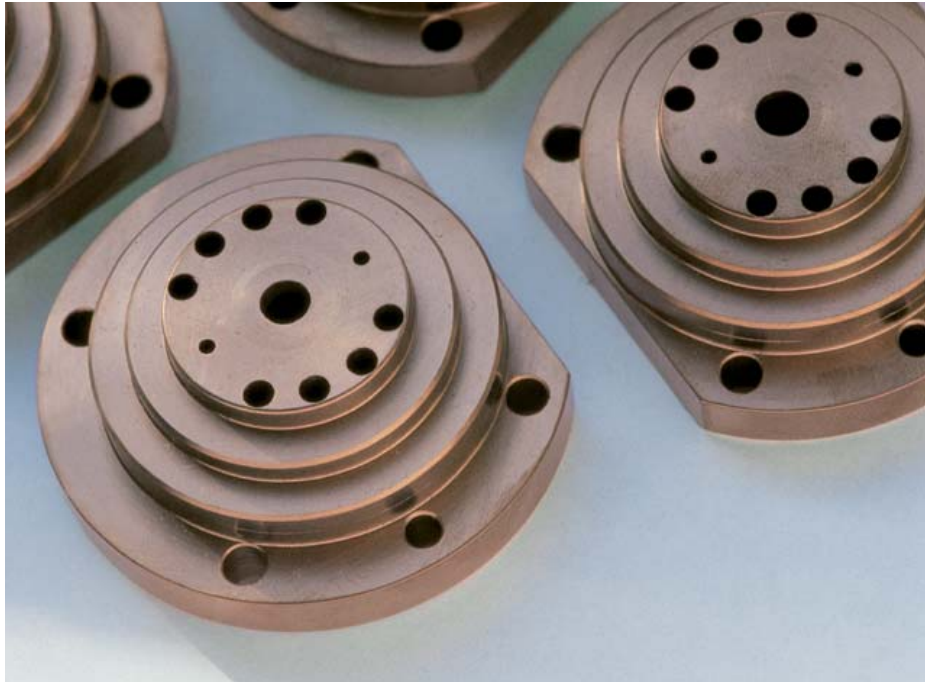

Example of a POSITIP program:
Machining multiple recesses on the same workpiece

```

000 BEGIN PGM 40 MM
001 X+80.000
002 Z+20.000
003 X+40.000
004 Z-5.000
005 LBL #8
006 IZ-20.000
007 X+25.000
008 X+40.000
009 ZYCL 7.0 LBLWDH 8 3/3
010 ZYCL 7.1 AUSZ +0.000
011 ZYCL 7.2 AUSZ +0.000
012 X+80.000
013 END PGM 40 MM
    
```

ND 200 Series

– Universal Digital Readouts for One Axis

The ND 200 series offers digital readouts for one axis. Due to their performance range they are predestined for measuring and inspection stations, but are also intended for simple positioning tasks such as infeed for a circular saw, the stroke of press travel, or the position of an additional rotary table on a machine tool. The switching inputs and outputs of the ND 287 permit operation also in simple automated environments.

Design

The ND 200 series features a sturdy aluminum die-cast housing. The splash-proof full-travel keyboard is built for the workshop. A large graphic TFT monitor displays the measured values, the status and the soft-key row.

Functions

The standard position display **ND 280** provides the basic functions for simple measuring tasks. The **ND 287** features numerous functions for measuring and statistical evaluation of measured values such as sorting and tolerance check mode, minimum/maximum value storage, and measurement series storage. These data make it possible to calculate mean values and standard deviations and display them in histograms or control charts. With its modular design, the ND 287 permits connection of a second encoder for sum/difference measurement or of an analog sensor, for example for temperature compensation.

Data interfaces

The ND 28x have serial interfaces for measured value transfer to a PC or printer, for input/output of parameters and compensation value lists, and for diagnostics:

- USB (UART)
- RS-232-C/V.24
- Ethernet 100BaseT (option, only with ND 287)



ND 287

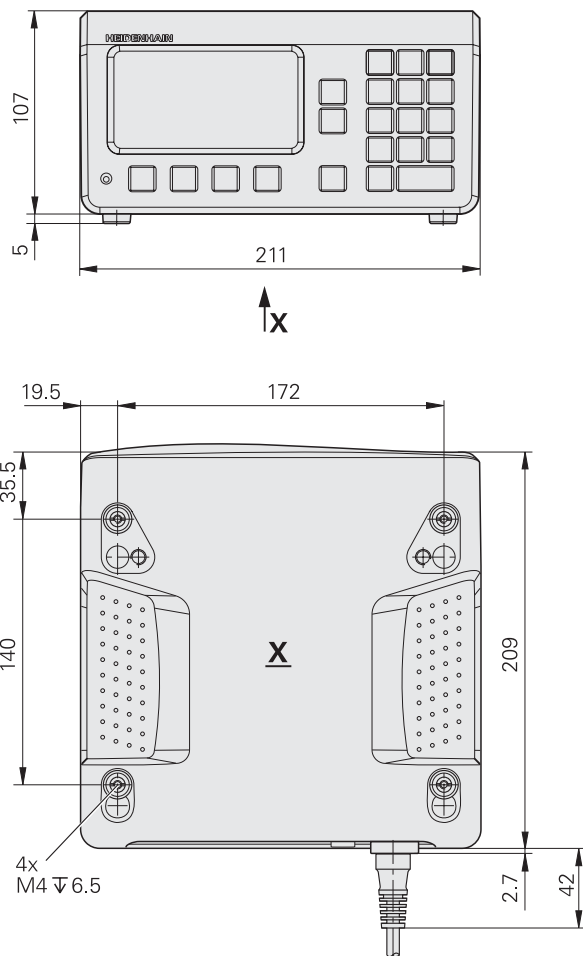

Dimensions in mm



Tolerancing ISO 8015

ISO 2768 - m H

< 6 mm: ±0.2 mm

	ND 280	ND 287
Encoder inputs	1 x \sim 1 V _{PP} , \sim 11 μ A _{PP} or EnDat 2.2 ¹⁾	1 x \sim 11 μ A _{PP} , \sim 1 V _{PP} or EnDat 2.2 ¹⁾ Option: Second input through encoder module
Input frequency	\sim 1 V _{PP} : \leq 500 kHz; 11 μ A _{PP} : \leq 100 kHz	
Subdivision factor	1 024-fold	
Display step ²⁾	Adjustable, max. 9 digits Linear axis: 0.5 to 0.002 μ m Angular axis: 0.5° to 0.00001° or 00°00'00.1"	
Analog Input	–	Option: \pm 10 V through analog module
Resolution	–	5 mV
Display	Monochrome TFT screen	Color TFT screen
	Position values, dialogs and input, graphic functions and soft keys	
Status display	Operating mode, REF, datum, scaling factor, compensation, stopwatch, unit of measure, soft-key level	
Functions	<ul style="list-style-type: none"> • REF reference-mark evaluation for distance-coded or single reference marks • 2 datums • Distance-to-go mode • Integrated help and diagnostics • Remote operation via serial interface 	
	–	<ul style="list-style-type: none"> • Sorting and tolerance checking • Measurement series with min./max. value storage • Saving measured values (max. 10 000) • Functions for statistical process control (SPC) • Graphic depiction of distribution/histogram • Sum/difference display (with 2nd encoder module) • Thermal compensation (with analog module)
Axis-error compensation	<i>Linear axis:</i> Linear and multipoint over up to 200 points <i>Angle axis:</i> Multipoint linear with 180 compensation points (every 2°)	
Data interface	<ul style="list-style-type: none"> • RS-232-C/V.24 • USB (UART) port type B 	
	–	Option: Ethernet 100BaseT, via Ethernet module
Switching outputs For tasks in automation	–	<ul style="list-style-type: none"> • Zero crossover • Trigger points 1 and 2 • Sorting signals "<" and ">" • Errors
Switching inputs For tasks in automation	–	<ul style="list-style-type: none"> • Zero reset, preset • Cross over reference point and ignore reference signals • Measured value output or display freeze (pulse or contact) • START MEAS. SERIES • Minimum/maximum/difference value • Gating of the two encoder inputs • Sum or difference display • Display measured value 1 or measured value 2
Main power input	100 V~ to 240 V~ (–10 % to +15 %), 50 Hz to 60 Hz (\pm 2 Hz); 30 W	
Operating temperature	0 °C to 45 °C	
Protection EN 60529	IP 40, front panel IP 54	
Weight	2.5 kg (approx.)	

¹⁾ Automatic detection of interface

²⁾ Depends on the signal period of the connected encoder (display step \approx signal period/1024)

ND 500 Series

– Simple Position Display Unit for Two and Three Axes

The position displays of the ND 500 series are suited for use on manually operated milling, drilling, boring machines and lathes with two or three axes. Due to the TTL encoder input, primarily the LS 328 and LS 628 linear encoders with a measuring step of 5 µm are used.

Design

With its sturdy housing and splash-proof membrane keyboard, the ND 500 is built for the workshop. The ND 500 series shows display position values, the soft-key row and other useful information on a monochrome graphic screen.

Functions

The most important functions offer quick and exact access. Soft keys with clear information in the local language enable you to make entries that fit your momentary situation.

The **distance-to-go display** facilitates positioning. You approach the next position quickly and reliably by simply traversing to the display value zero. The functions for each application are easily activated by parameter input. Special functions are available for producing **hole patterns** (linear patterns and circular patterns).

You can easily switch between radius and diameter display when the position display is configured for turning. On lathes with a separate top slide, the sum display feature of the **ND 523** allows you to display the saddle and top slides together or separately. Setting datums on a lathe part is particularly easy with the **freeze tool position** function and subsequent retracting.

Data interfaces

A USB interface enables the display unit to indicate measured values and import or export parameters and tables.



ND 523

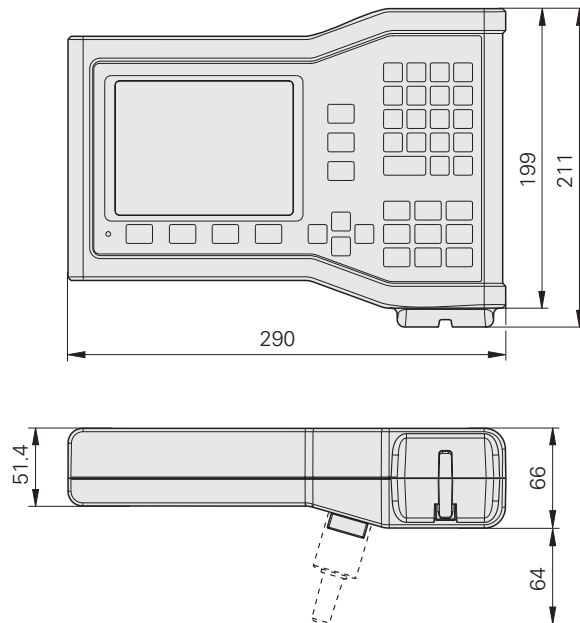

Dimensions in mm

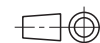

Tolerancing ISO 8015
ISO 2768 - m H
< 6 mm: ±0.2 mm

	ND 522	ND 523
Axes	2 axes from A to Z, 3 axes from A to Z and Z _S	
Encoder inputs	2 x □□ TTL; 9-pin D-sub female	3 x □□ TTL; 9-pin D-sub female
Input frequency	≤ 100 kHz	
Signal period	2 μm, 4 μm, 10 μm, 20 μm, 40 μm, 100 μm, 10240 μm, 12800 μm	
Line count	Any	
Evaluation	1/2/4-fold	
Display step¹⁾	<i>Linear axis:</i> 1 mm to 0.0001 mm; 0.005 with LS 328/LS 628 <i>Angular axis:</i> 1° to 0.0001° (00° 00' 01")	
Display	Monochrome flat screen for position values, dialog and input displays, graphic functions and graphic positioning support	
Status display	Operating mode, REF, reference-point number, tool number, inch, scale, feed-rate display, stopwatch	
For milling/drilling/boring	Tool compensation R+, R-	
For turning	Radius/diameter display Separate or sum display for Z and Z _O	
Functions	<ul style="list-style-type: none"> • 10 datums • 16 tools • REF reference mark evaluation for distance-coded and single reference marks • Distance-to-go display with nominal position input in absolute or incremental values • Contour monitoring • Scaling factor • mm/inch switching • HELP: on-screen operating instructions • INFO: Stopwatch, pocket calculator, cutting data calculator (for milling), taper calculator (for turning) 	
For milling/drilling/boring	<ul style="list-style-type: none"> • Calculation of positions for hole patterns (circular and linear patterns) • Tool radius compensation 	
For turning	<ul style="list-style-type: none"> • Freezing the tool position display during retraction 	
Error compensation	<i>Axis error:</i> Linear and multipoint over up to 200 points <i>Backlash compensation:</i> For length measurement via ball screw and rotary encoder	
Data interface	USB type B connector; 115200 baud <ul style="list-style-type: none"> • For output of measured values and parameters • For input of parameters, remote control of keys and commands 	
Accessories	Base, mounting arm	
Main power input	100 V~ to 240 V~ (-15 % to +10 %), 48 Hz to 52 Hz	
Power consumption	25 W	
Operating temperature	0 °C to 45 °C	
Protection EN 60529	IP 40, front panel IP 54	
Weight	2.6 kg (approx.)	

¹⁾ Depends on the signal period or line count of the connected encoder

ND 780 Series

– Adaptable Readout for up to Three Axes

The ND 780 display unit is especially suited for use on milling, drilling and boring machines and lathes with up to three axes. A separate I/O unit provides switching input/outputs for simple tasks in automation.

Design

The ND 780 display unit is designed as a sturdy upright unit with splash-proof full-travel keypad for use in a workshop. It is equipped with a monochrome flat screen for position values, dialog and input displays, graphic functions and graphic positioning support.

Functions

The **ND 780** display unit is characterized by its plain language dialog guidance. The **distance-to-go display** facilitates positioning. You approach the next position quickly and reliably by simply traversing to the display value zero. The functions for each application are easily activated by parameter input. Special functions are available for producing **hole patterns** (linear patterns and circular patterns). Datums can be determined quickly and accurately with an edge finder. The ND 780 readout supports you with special **probing functions**.

You can easily switch between radius and diameter display when the position display is configured for turning. The readout also offers support for lathes with separate top slide: The **sum display feature** allows you to display the saddle and top slides together or separately. To set a datum, touch the workpiece and **freeze the tool position**. Then retract and measure the workpiece.

Data interfaces

The ND 780 has an RS-232-C/V.24 serial interface for measured value transfer to a PC or printer, for input/output of parameters and compensation value lists, and for diagnostics.

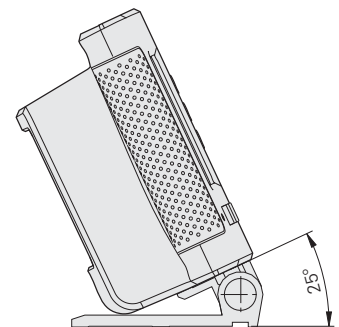
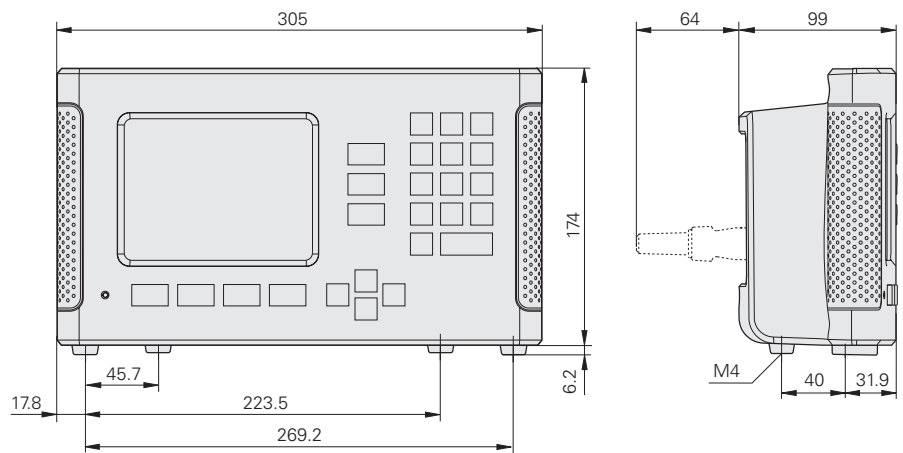

Dimensions in mm



Tolerancing ISO 8015

ISO 2768 - m H

< 6 mm: ±0.2 mm

ND 780	
Axes	Up to 3 axes from A to Z and Z _O , Z _S
Encoder inputs	3 x \sim 1 V _{PP} or \sim 11 μ A _{PP} ; 15-pin D-sub female (automatic interface recognition)
Input frequency	\leq 100 kHz
Signal period	2 μ m, 4 μ m, 10 μ m, 20 μ m, 40 μ m, 100 μ m, 10240 μ m, 12800 μ m
Line count	Any
Subdivision factor	Max. 1024-fold
Display step¹⁾	<i>Linear axis:</i> 1 mm to 0.0001 mm <i>Angular axis:</i> 1° to 0.0001° (00° 00' 01")
Display	Monochrome flat screen for position values, dialog and input displays, graphic functions and graphic positioning support
Status display	Operating mode, REF, reference-point number, tool number, inch, scale, feed-rate display, stopwatch
For milling/drilling/boring	Tool compensation R+, R-
For turning	Radius/diameter display Separate or sum display for Z and Z _O
Functions	<ul style="list-style-type: none"> • 10 datums • 16 tools • REF reference mark evaluation for distance-coded and single reference marks • Distance-to-go display with nominal position input in absolute or incremental values • Scaling factor • mm/inch switching • HELP: on-screen operating instructions • INFO: Stopwatch, pocket calculator, cutting data calculator (for milling), taper calculator (for turning)
For milling/drilling/boring	<ul style="list-style-type: none"> • Calculation of positions for hole patterns (circular and linear patterns) • Tool radius compensation • Probing function for reference-point acquisition with the KT edge finder: "Edge," "Centerline" and "Circle center"
For turning	<ul style="list-style-type: none"> • Freezing the tool position for back-off • Probing functions for reference-point setting with the tool
Error compensation	<i>Axis error:</i> Linear and multipoint over up to 200 points <i>Backlash compensation:</i> For length measurement via ball screw and rotary encoder
Data interface	RS-232-C/V.24 300 to 115200 baud <ul style="list-style-type: none"> • For output of measured values and parameters • For input of parameters, remote control of keys and commands
Switching I/O	<ul style="list-style-type: none"> • Two inputs (pulse or contact) for measured value output • 1 input for KT edge finder • 1 input for edge finder with contact triggering • Further input/outputs over the IOB 49 input/output unit
Accessories	KT edge finder (for milling) tilting base, handle, tilt/swivel mount, pivot arm
Main power input	Primary-clocked power supply 100 V~ to 240 V~ (-15% to +10%), 48 Hz to 52 Hz
Power consumption	30 W
Operating temperature	0 °C to 45 °C
Protection EN 60529	IP 40, front panel IP 54
Weight	2.6 kg (approx.)

¹⁾ Depends on the signal period or line count of the connected encoder

POSITIP 880

– the Programmable Readout for up to Six Axes

The POSITIP 880 is a versatile display unit designed primarily for milling machines, drilling and boring machines and lathes with up to six axes. A separate I/O unit provides switching input/outputs for simple tasks in automation.

Design

The POSITIP 880 display unit is designed as a sturdy upright unit with splash-proof full-travel keypad for use in the workshop. It supports all operations with straight-forward interactive menus on its large, easy-to-read color flat screen. And it does it on big machines as well: Since the POSITIP 880 permits the connection of a separate display and control unit; you can have all position values and functions available at a remote console.

Functions

The POSITIP provides advanced features beyond those offered by the ND 780 display unit. The POSITIP supports any axis combination and helps you at 2-D machining operations with its graphic contour monitoring and magnify function. In the milling mode it supports you in machining and clearing out rectangular pockets while it takes allowances into account during turning.

The programming capabilities of POSITIP make it ideal for small-batch production on conventional machine tools: you can store up to 999 program blocks per program in its memory. Programs are created by either keying them in step by step or generating them through actual position capture (teach-in programming). With the subprogramming capability, you can enter repetitive machining sequences on the same workpiece once only. Fixed cycles keep your programs short and save you programming time.

Data interfaces

The POSITIP 880 has an RS-232-C/V.24 serial interface for measured value transfer to a PC or printer, for input/output of parameters and compensation value lists, and for diagnostics. A parallel Centronics interface is also provided for pure measured value output.

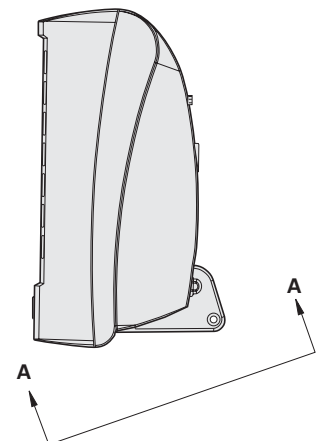
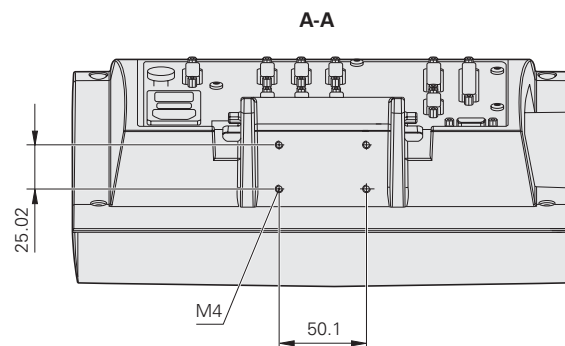
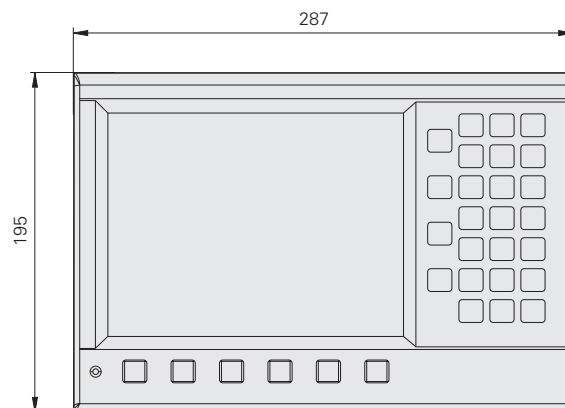

		POSITIP 880
Axes		Up to 6 axes from A to Z and Z _O , Z _S
Encoder inputs		6 x $\sim 1 V_{PP} \sim 11 \mu A_{PP}$ or EnDat 2.1 (automatic interface recognition)
Input frequency		≤ 100 kHz
Signal period		0.128 μm , 2 μm , 4 μm , 10 μm , 20 μm , 40 μm , 100 μm , 10240 μm , 12800 μm
Line count		Any
Subdivision factor		Max. 1024-fold
Display step¹⁾		<i>Linear axis:</i> 1 mm to 0.005 μm <i>Angular axis:</i> 0.01° to 0.0001° (00° 00' 01")
Display		Color flat screen for position values, dialog and input displays, graphic functions, graphic positioning support and contour monitoring
Status display		Operating mode, REF, reference-point number, tool number, inch, scale, feed-rate display, stopwatch
For milling/drilling/boring		Tool compensation R+, R-
For turning		Radius/diameter display Separate or sum display for Z and Z _O
Functions		<ul style="list-style-type: none"> • REF reference-mark evaluation for distance-coded or single reference marks • Distance-to-go mode, nominal position input (absolute or incremental) • Scaling factor • Contour monitoring with zoom function • Any axis combinations • HELP: on-screen operating instructions • INFO: Stopwatch, pocket calculator, cutting data calculator (for milling), taper calculator (for turning)
For milling/drilling/boring		<ul style="list-style-type: none"> • 99 datums and 99 tools • Calculation of positions for hole patterns (circular and linear patterns) • Tool radius compensation • Probing function for reference-point acquisition with the KT edge finder: "Edge," "Centerline" and "Circle center" • Positioning aids for milling and the roughing out of a rectangle pocket
For turning		<ul style="list-style-type: none"> • 1 datum, 99 tools • Freezing tool position for back-off • Oversize allowances
Programming operating mode		Up to 999 program blocks in each program, subprogramming capability, teach-in programming
Cycles	For milling/drilling For turning	Line segments, circular arcs, chamfers, circular and linear hole patterns, rectangular pockets Line segments, circular arcs, chamfers, multipass
Error compensation		Linear and multipoint, up to 128 measuring points
Data interfaces	Serial Parallel	RS-232-C/V.24 300 to 115200 baud <ul style="list-style-type: none"> • For output of programs, measured values and parameters • For loading of programs and parameters Centronics for measured value output
Switching I/O		<ul style="list-style-type: none"> • Via IOB 89 external input/output unit • 1 input for KT edge finder
Accessories		KT edge finder (milling) tilting base, tilt/swivel mount, mounting arm, second display unit
Main power input		100 V~ to 240 V~ (-5% to +10%), 50 Hz to 60 Hz (± 2 Hz), power consumption: 35 W
Operating temperature		0 °C to 45 °C
Protection EN 60529		IP 40, front panel IP 54
Weight		3.2 kg (approx.)

¹⁾ Depends on the signal period or line count of the connected encoder

Mounting

– ND 200 and ND 500 Series

ND 200 Series

The ND 200 display units were conceived as bench-top units. They can easily be stacked. Recesses on the top prevent the stacked units from moving out of place.

You can secure the ND 28x from below by using M4 screws on a base plate.

Two ND 28x displays fit next to each other in a 19" housing. They occupy two height units. A mounting base is available as an accessory for mounting in a 19" housing.

Accessories:

Mounting base for 19" housing
ID 654020-01

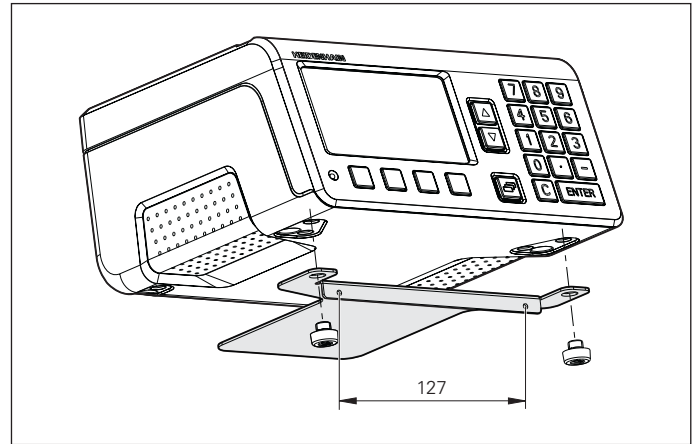

ND 500 Series

You can set up the ND 52x either on a mounting arm on the machine, with the aid of a mounting base, or install it in a control panel. The parts required for fastening the display are included in delivery. They enable you to rotate and tilt the display. The mounting arm and base are available as accessories:

Accessories:

Mounting arm, straight (see page 27)
ID 382893-01

Mounting arm, offset (see page 27)
ID 382929-01

Mounting base
ID 625491-01

Mounting frame

ID 647702-01

For mounting the ND 52x in a housing or operating panel.

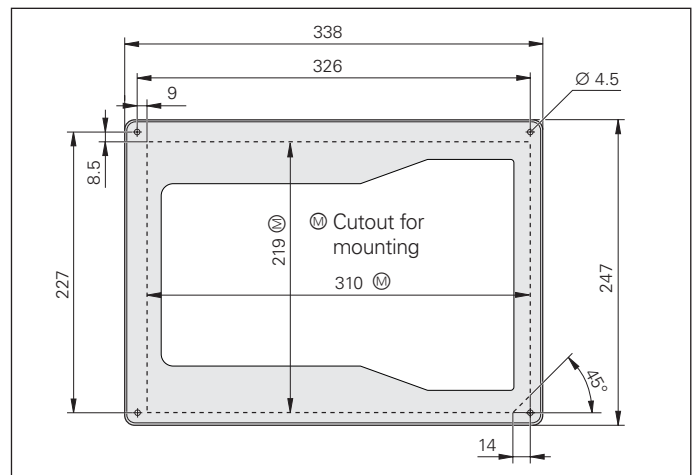
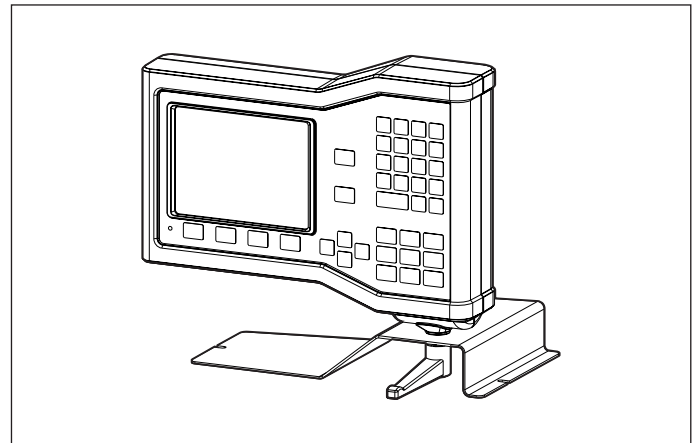

– ND 780

The ND 780 display units were conceived as upright units. There are many possible mounting configurations:

- Threaded mounting hole M4 on bottom of housing
- Tilting base
- Mounting frame
- Tilt/swivel assembly
- Mounting arm and tilt/swivel assembly

Accessories

Tilting base

ID 281 619-01

The tilting base can be used to tilt the display forward and backward by up to 20°. It can be attached with M5 screws.

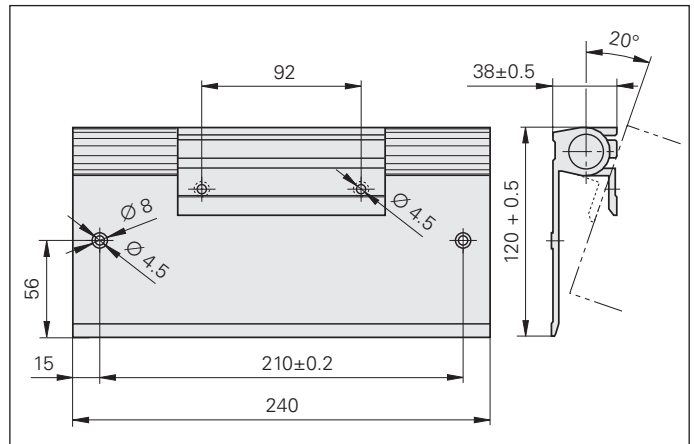

Tilt/swivel assembly

ID 520011-01

The mount permits tilting and rotation of the readout. It can be attached to a machine element or mounting arm with its M8 screws.

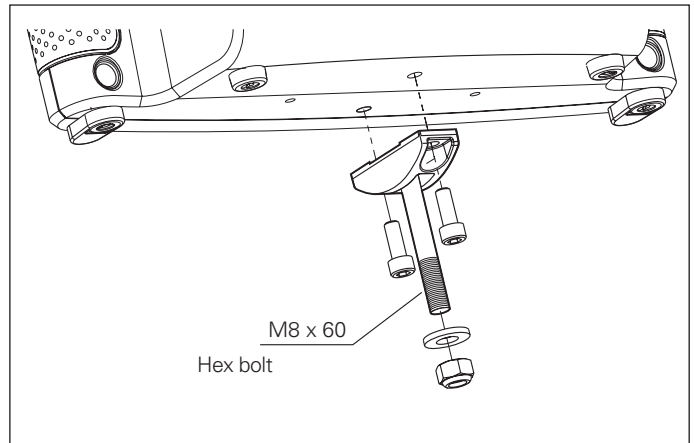

Grip bar

ID 520012-01

The handle is attached to the base of the ND 780, and is used to easily swivel the readout.

Mounting arm, straight (see page 27)

ID 382 893-01

Mounting arm, offset (see page 27)

ID 382 929-01

Mounting frame

ID 532 811-01

For mounting the ND 780 in a housing or operating panel.

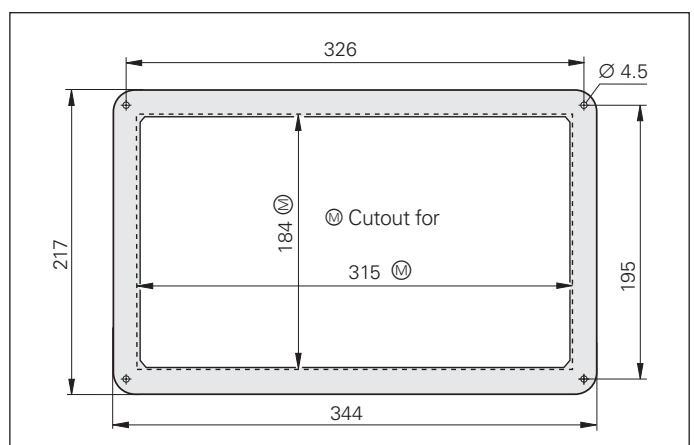

Mounting

– POSITIP 880

The POSITIP 880 was conceived as an upright unit. There are many possible mounting configurations:

- Threaded mounting hole M4 screw on bottom of housing
- Tilting base
- Tilt/swivel assembly
- Mounting arm and tilt/swivel assembly

Accessories

Tilting base

ID 382892-01

It can be used to tilt the display forward and backward by up to 20°. It can be attached with M5 screws.

Tilt/swivel assembly

ID 382891-01

The mount permits tilting and rotation of the readout. It can be attached to a machine element or mounting arm with its M8 screws.

Mounting arm, straight (see page 27)

ID 382893-01

Mounting arm, offset (see page 27)

ID 382929-01

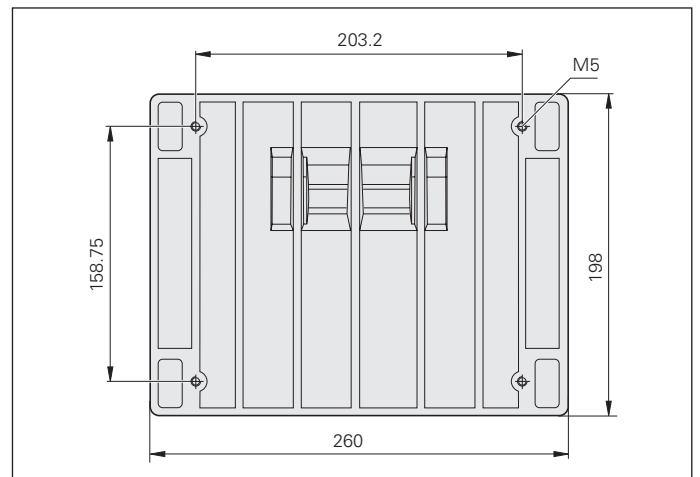
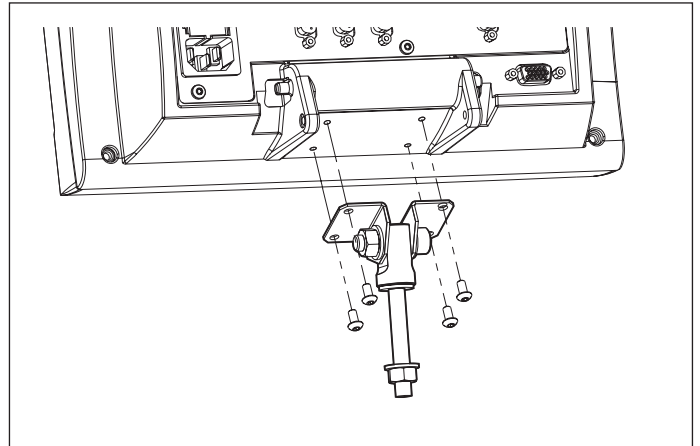

– Mounting Arms (Accessories for Series ND 500, ND 780, POSITIP)

Use the mounting arm to place the display easily at a convenient operating position. It can be attached to the machine and swiveled by either a bracket or a hex bolt. The display is attached to the mounting arm by its own tilt/swivel mount.

Accessories:

Mounting arm, straight

ID 382893-01

Mounting arm, offset

ID 382929-01

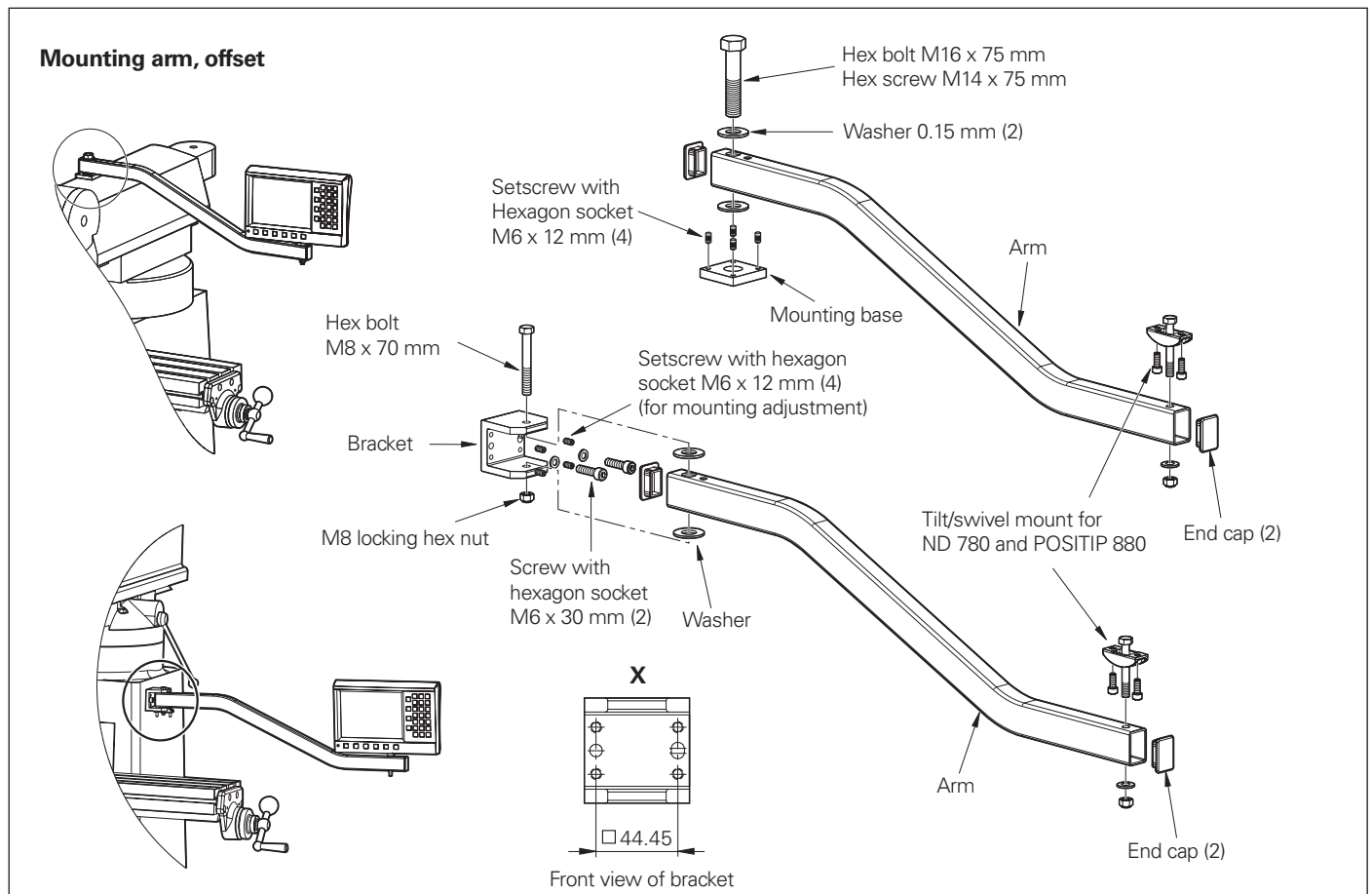
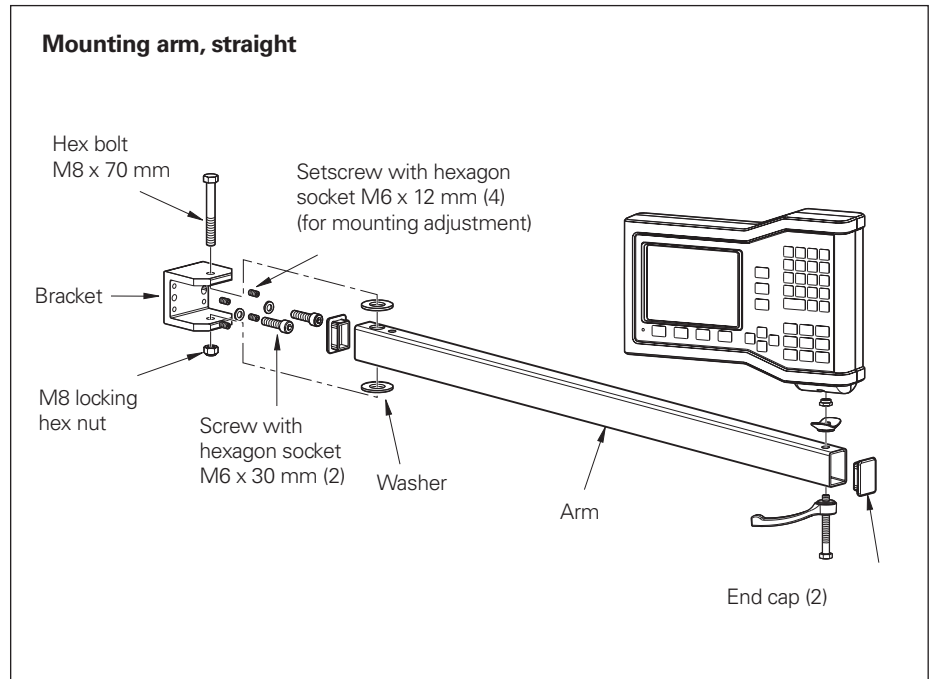

Encoders

Supported encoders

Linear and angle encoders from HEIDENHAIN with various interfaces can be connected to HEIDENHAIN position display units (see table).

Connect linear or angle encoder

HEIDENHAIN linear and angle encoders can be connected easily and directly to the position display units.

The versatile display units from HEIDENHAIN can be adapted to the encoder and the respective operating conditions. The following values can be set via parameters:

- Signal period of the linear encoder
- Line count of the angle or rotary encoder
- Desired display step (resolution)
- Counting direction
- Angle display, etc.

Specifics of connecting rotary encoders

Rotary encoders can also be connected to the display units in order to measure linear distances via spindle and rotary encoder combinations, or for measuring angles on rotary tables with worm gears. You must take into consideration that the errors of the mechanical transfer elements (spindle-pitch error, reversal error, etc.) directly influence the positioning accuracy. The traverse distance and the display value can be adjusted to each other in the position display unit. With the POSITIP, you can also enter an additional factor (reduction gear).

Signal period for lead screw and rotary encoder combination for linear measurement

Spindle pitch: 10 mm

Line count of the encoder: 1000 lines

Theoretical signal period:

$$10 \text{ mm} : 1000 \text{ lines} = 0.01 \text{ mm} = 10 \text{ }\mu\text{m}$$

Line count for angular measurement with rotary encoder via a worm gear

Gear ratio 9 : 1

Line count of the encoder:

e.g. 1000 lines

Theoretical line count for angular measurement (any value possible):

$$9 \times 1000 \text{ lines} = 9000 \text{ lines}$$

Model	Supported encoders	Interface	Connecting elements Encoder input
ND 280 ND 287	Incremental linear, angle or rotary encoders	$\sim 1 \text{ V}_{PP}$ $\sim 11 \text{ }\mu\text{A}_{PP}$	D-sub connector (female) 15-pin
	Absolute linear angle encoders, or rotary encoders	EnDat 2.2	
ND 522 ND 523	Incremental linear and angle encoders	TTL	D-sub connector (female) 9-pin
ND 780	Incremental linear and angle encoders	$\sim 1 \text{ V}_{PP}$ $\sim 11 \text{ }\mu\text{A}_{PP}$	D-sub connector (male) 15-pin
POSITIP 880	Incremental linear, angle or rotary encoders	$\sim 1 \text{ V}_{PP}$ $\sim 11 \text{ }\mu\text{A}_{PP}$	D-sub connector (male) 15-pin
	Absolute linear, angle or rotary encoders	EnDat 2.1	

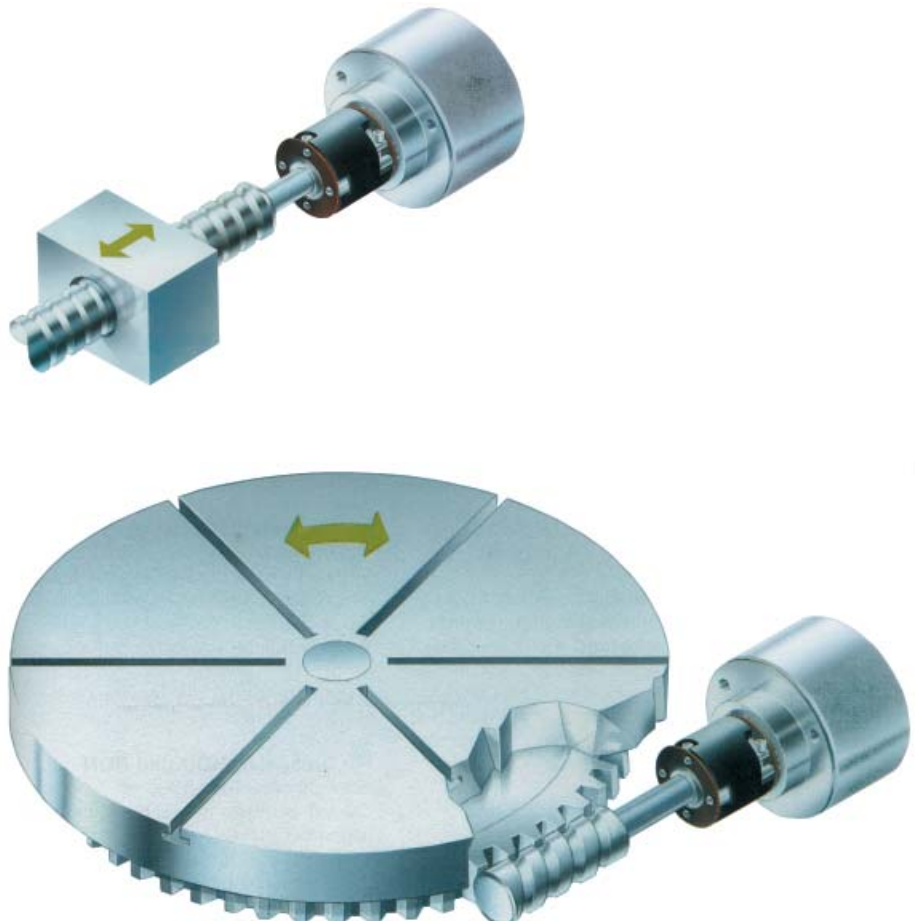

Absolute encoders

With the absolute encoders from HEIDENHAIN, the position value is available from the encoder immediately upon switch-on, and can be called at any time by the display unit. There is no need to move the axes to find the reference position. The absolute position information is read directly from the scale graduation, and is output serially as an absolute position value via the bidirectional EnDat interface.

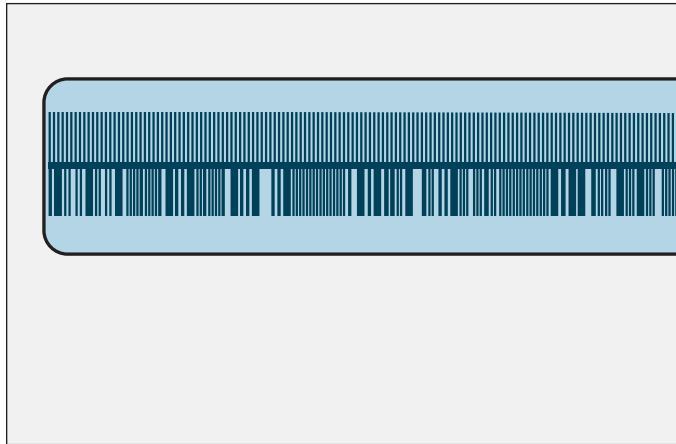

Incremental encoders

Incremental linear and angle encoders from HEIDENHAIN transmit two sinusoidal signals phase-shifted by 90° as measuring signals, as well as one or more reference mark signals. The readout often subdivides the sinusoidal measuring signal in order to achieve measuring steps smaller than the signal period.

Incremental measurement means counting while measuring. In order to attain an absolute reference, a **reference mark** is applied to the scale. When the reference mark is traversed, a signal associated with exactly one measuring step is generated. In this manner, the association between the position and the display value specified by the **datum setting** is re-established by traversing the reference marks in each axis.

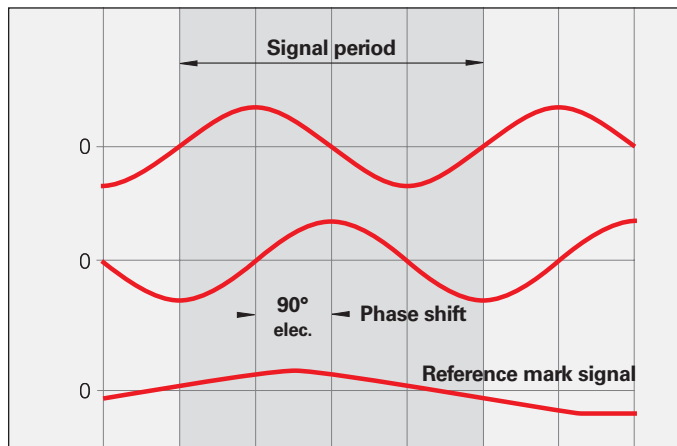

Sinusoidal measuring signals



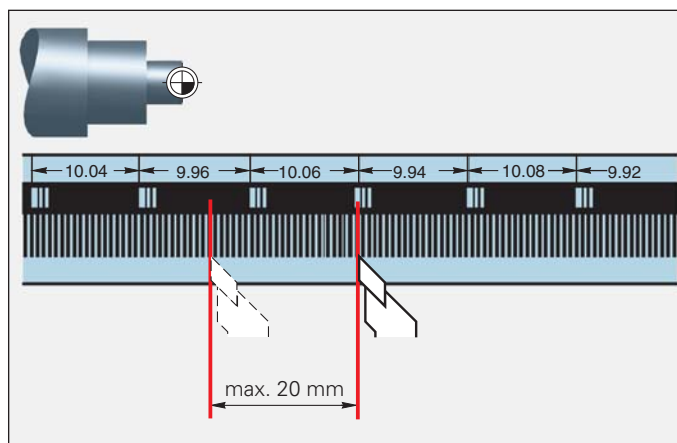





To speed and simplify the referencing procedure, many HEIDENHAIN scales (and graduated disks of angle encoders) have distance-coded reference marks. On these position encoders, the absolute position is already available after traversing two neighboring reference marks. For example, on linear encoders this distance is at most 20 mm (LS, LF) or 80 mm (LB), and for angle encoders a rotation of at most 20°.



Traverse with distance-coded reference marks

Interfaces

The position display units feature interfaces for encoders, for communication and external operation.

	ND 280	ND 287	ND 522 ND 523	ND 780	POSITIP 880
Encoders	 1 V _{PP}  11 μA _{PP} EnDat 2.2	 1 V _{PP}  11 μA _{PP} EnDat 2.2	 TTL	 1 V _{PP}  11 μA _{PP}	 1 V _{PP}  11 μA _{PP} EnDat 2.1
Edge Finder	–	–	–	<ul style="list-style-type: none"> • KT 130 • Contact triggering 	KT 130
Sensors	–	± 10 V (option)	–	–	–
Data	<ul style="list-style-type: none"> • RS-232-C/V.24 • USB (UART) 	<ul style="list-style-type: none"> • RS-232-C/V.24 • USB (UART) • Ethernet (option) 	USB	RS-232-C/V.24	<ul style="list-style-type: none"> • RS-232-C/V.24 • Centronics
Switching inputs	–	12	–	4 (over IOB 49 input/output unit)	8 (over IOB 89 input/output unit)
Switching outputs	–	6	–	9 (over IOB 49 input/output unit)	9 (over IOB 89 input/output unit)
Analog output	–	–	–	1 (over IOB 49 input/output unit)	–
2nd remote console	–	–	–	–	Yes

– Encoders

The ND and POSITIP display units feature interfaces for connecting encoders from HEIDENHAIN. The ND 287 display unit can be equipped with a second encoder input.

Accessories for ND 287:

Encoder module

Input assembly for second encoder with 1 V_{PP}, 11 μA_{PP} or EnDat 2.2 interface
ID 654 017-01

Pin layout of series ND 200 \sim 1 V_{PP}/ \sim 11 μA_{PP}/EnDat

Mating connector:
15-pin D-sub connector (male)

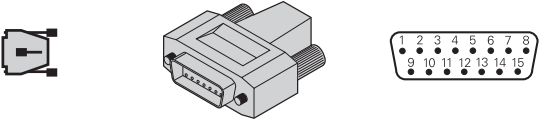

	Power supply					Incremental signals						Absolute position values			
	4	12	2	10	6	1	9	3	11	14	7	5	13	8	15
\sim 1 V _{PP}	U _P	Sensor U _P	0V	Sensor 0V	/	A+	A-	B+	B-	R+	R-	/	/	/	/
\sim 11 μA _{PP}					Internal shield	I ₁₊	I ₁₋	I ₂₊	I ₂₋	I ₀₊	I ₀₋	/	/	/	/
EnDat						/	/	/	/	/	/	DATA	DATA	CLOCK	CLOCK

Shield on housing; U_P = power supply voltage

Sensor: The sensor line is connected in the encoder with the corresponding power line

Pin layout of ND 500 series \square TTL

Mating connector:
9-pin D-sub connector (male)

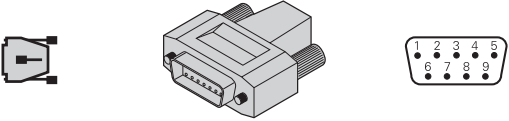

	Power supply		Incremental signals						Others
	7	6	2	3	4	5	8	9	1
\square TTL	U _P	0V	U _{a1}	\overline{U}_{a1}	U _{a2}	\overline{U}_{a2}	U _{a0}	\overline{U}_{a0}	/

Shield on housing; U_P = power supply voltage

Pin layout

ND 780 \sim 1 V_{PP}/ \sim 11 μA_{PP}

PT 880 \sim 1 V_{PP}/ \sim 11 μA_{PP}/EnDat

Mating connector:
15-pin D-sub connector (female)

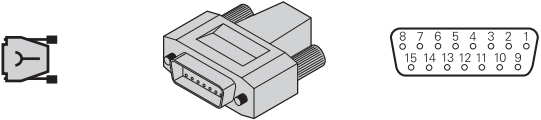

	Power supply					Incremental signals						Absolute position values			
	1	9	2	11	13	3	4	6	7	10	12	5	8	14	15
\sim 1 V _{PP}	U _P	Sensor U _P	0V	Sensor 0V	/	A+	A-	B+	B-	R+	R-	/	/	/	/
\sim 11 μA _{PP}					Internal shield	I ₁₊	I ₁₋	I ₂₊	I ₂₋	I ₀₊	I ₀₋	/	/	/	/
EnDat						A+	A-	B+	B-	/	/	DATA	DATA	CLOCK	CLOCK

Shield on housing; U_P = power supply voltage

Sensor: The sensor line is connected in the encoder with the corresponding power line

Interfaces

– Analog Input (Option)

The ND 287 display unit can be equipped with an optional input assembly with an additional analog input connecting a sensor. The input voltage range is interpolated 4096-fold; for a sensor with $\pm 10\text{ V}$ the resolution is therefore 5 mV. The analog module provides 5 V, 12 V and 24 V– as power supply for the sensor. The 5 V (B) and 12/24 V (A) power supplies are metalically isolated. They must not be used at the same time. A 9-pin D-sub connector is required as mating connector.

Accessories:

Analog module

Input assembly for $\pm 10\text{ V}$ analog sensor
ID 654018-01

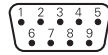

Pin	Assignment
1	– 12 V (A) / 85 mA
2	0 V (A)
3	0 V (A)
4	+ 12 V (A) / 85 mA
5	Shield
6	0 V (B)
7	0 V (B)
8	Sensor (B) $\pm 10\text{ V}$ max.
9	+ 5 V (B) / 400 mA

– Serial Data Transfer

The position display units from HEIDENHAIN feature serial data interfaces for connecting of a printer or PC. Depending on the readout's features, it can output measured values, measurement series, parameters and programs. It can also load compensation value tables, parameters and programs, and it can be operated remotely through the simulation of keyed-in commands.

There are many possible ways to **start the measured value transfer**:

- From the keyboard with the EXPORT soft key
- By the software command CTRL B
- Via external signal through a pulse or make contact at a D-sub connection (on POSITIP at IOB 89)
- Through deflection of the edge finder (only on ND 780)

USB

The ND 28x and ND 52x display units feature a USB interface with the connector type B. The USB interface functions as a UART (Universal Asynchronous Receiver Transmitter). A special driver software is required for operation (free download at www.heidenhain.de). Data output is in ASCII code.

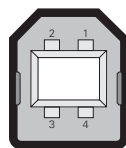

Pin	Assignment
1	V _{CC} + 5 V
2	D– Data –
3	D+ Data +
4	GND Ground

Interfaces

– Serial Data Transfer

RS-232-C/V.24

This serial interface follows the EIA standard RS-232-C and the CCITT V.24. It uses a 9-pin D-sub female connection. Data output is in ASCII code. The **data format** is adjustable (default value in bold type):

- Start bit
- **7/8** data bits
- Parity bit (**none**/even/odd)
- **1/2** stop bits

Accessories

Connecting cable, complete with two D-sub connectors (female) 9-pin
ID 366964-xx

Connecting cable, complete with D-sub connector (female) 9-pin and 25-pin (male)
ID 368017-xx

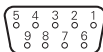

Pin	Assignment
1	Do not assign
3	TXD – Transmitted data
2	RXD – Received data
7	RTS – Request to send
8	CTS – Clear to send
6	DSR – Data set ready
5	SIGNAL GND – Signal ground
4	DTR – Data terminal ready
9	Do not assign

Signal	Signal level "1" = "active"	Signal level "0" = "not active"
TXD, RXD	-3 V to -15 V	+3 V to +15 V
RTS, CTS DSR, DTR	+3 V to +15 V	-3 V to -15 V

Ethernet (option)

The ND 287 display unit can be equipped with an Ethernet module.

Accessories

Ethernet module
ID 654019-01

The module is provided with an Ethernet interface 100BaseT with RJ45 connector (female, 8-pin). This enables you to connect the ND 287 directly to your company's intranet or, with a crossover cable, to a PC.

The data transfer rate is dependent on the amount of traffic at the time on the net. The iTNC requires an NFS server (Network File System) or a Windows PC (SMB = Server Message Block) as the remote station. It must work according to the TCP/IP protocol principle.

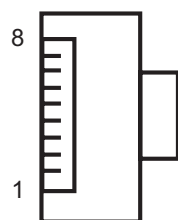

Pin	Assignment
1	TX+
2	TX-
3	REC+
4	Do not assign
5	Do not assign
6	REC-
7	Do not assign
8	Do not assign
Housing	Ext. shield

Interfaces

– Switching Inputs/Outputs on ND 287

Switching inputs

The ND 287 position display unit features many inputs for external operation and outputs for switching functions.

The input can respond by pulse or make contact.

Exception: The switching inputs for transmitting measured values over the data interface are separate for contact and pulse.

The switching input E is active when a Low signal U_L is applied (contact or pulse to 0V).

Signal level

– $0.5V \leq U_L \leq 0.9V$ at $I_L \leq 6\text{ mA}$
 $3.9V \leq U_H \leq 15.0V$

$t_{\min} \geq 30\text{ ms}$

Zero reset/preset

Each axis can be set by an external signal to the display value zero or to a value stored in a parameter (SET).

External control of measurement series

Switching the display to MIN/MAX/DIFF

With a continuously applied Low signal at the corresponding switching input you activate the external control of measurement series. Starting a measurement series and switching to the MIN/MAX/DIFF display are controlled externally over additional switching inputs.

Ignoring reference mark signals

(disabling the reference pulse)

When the input is active, the display unit ignores all reference mark signals. A typical application is for linear measurement through the lead screw and a rotary encoder.

Activate or deactivate REF mode

After switch-on or a power interruption, the display unit can be switched externally to REF mode. The next signal then deactivates REF mode (switchover function).

Display with axis coupling

As an option, the ND 287 can have two encoder inputs. Using switching inputs, you can switch the display to individual measured values, sum, difference or any logical operation.

ND 287	
12 switching inputs	Reset, clear error message Datum setting Externally control measurement series or display of $X1^{1)}$ Start measurement series or display of $f(X1, X2)^{1)}$ Display minimum MIN or display of $X2^{1)}$ Display maximum MAX or display of $X1 + X2^{1)}$ Display maximum DIFF or display of $X1 + X2^{1)}$ Measured value output (pulse) Measured value output (contact) Ignore reference mark signals (input X1) Ignore reference mark signals (input X2) REF mode switch-off or activation
6 switching outputs	Display value is zero Measured value \geq switching limit A1 Measured value \geq switching limit A2 Measured value $>$ upper sorting limit Measured value $>$ Lower sorting limit Errors

¹⁾ Also selectable by parameter

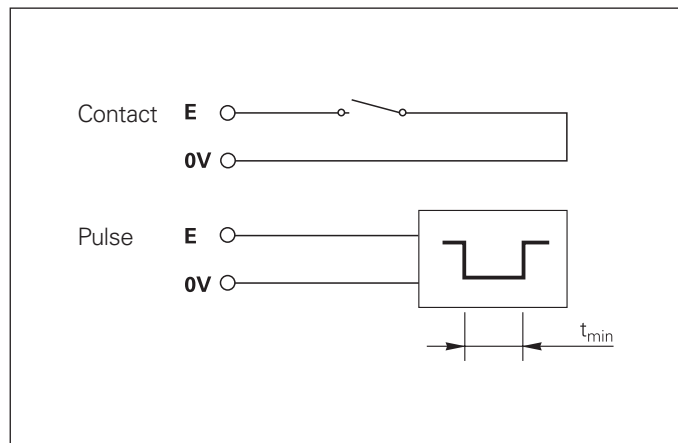

Switching outputs

The ND 287 features open-collector outputs that switch to 0 V (= active Low).

Delay of signal output:

$t_D \leq 20 \text{ ms}$

Signal level

$U_L \leq 0.4 \text{ V}$ at $I_L \leq 100 \text{ mA}$

$U_H \leq 32 \text{ V}$ at $I_H \leq 10 \mu\text{A}$

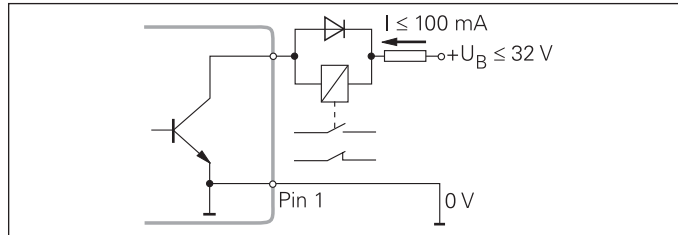

Trigger points (in actual value mode)

When the measured value reaches trigger points defined by parameter, the corresponding output becomes active. Up to two trigger points can be defined.

Switch-off ranges (in distance-to-go mode)

In the distance-to-go mode the trigger points function as switch-off ranges. They are located symmetrically around the display value 0.

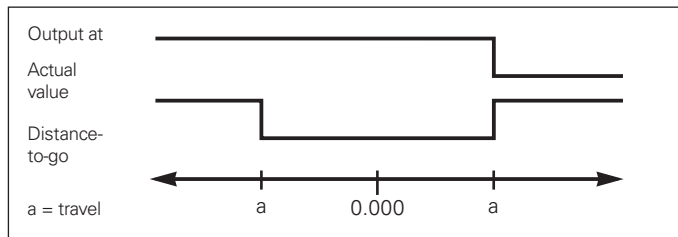

Sorting limits

When the measured value exceeds the limits defined via parameters, the corresponding outputs become active.

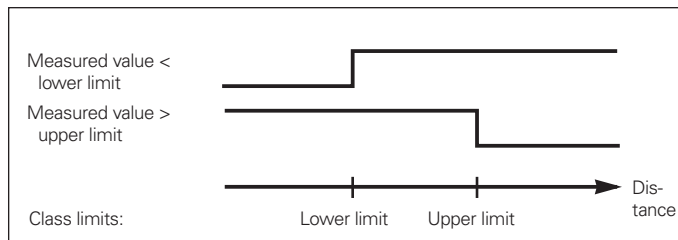

Trigger signal for error

The ND 200 series displays constantly monitor the measuring signals, the input frequency, the data output, etc. for errors, and report errors as they occur with error messages. If an error occurs that may distort the measurement or corrupt the data, the display activates a switching output. This feature allows monitoring of automated processes.

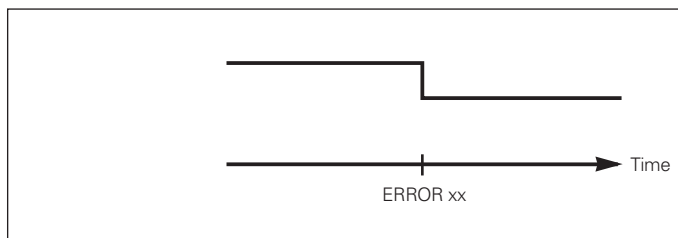

Zero crossover

At the display value "zero," the corresponding output becomes active. The minimum signal duration is 180 ms.

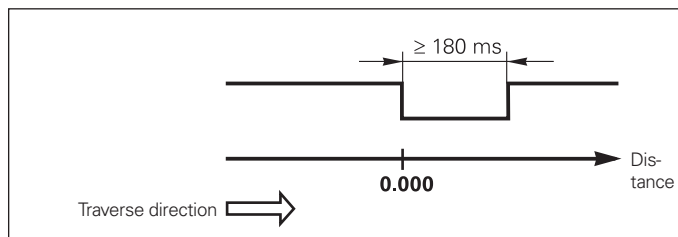

Interfaces

– Switching I/O on ND 780 over IOB 49

The ND 780 provides application-dependent additional functions that are available when the IOB 49 external input/output unit is connected.
ID 532900-01

IOB 49 external input/output unit

ID 532900-01

The IOB 49 input/output unit is attached to a standard NS 35 rail (DIN 46227 or EN 50022). It is connected to the ND 780 using the touch probe input. LEDs show the power supply, the data transmission and the status of the inputs and outputs.

Accessories:

Connecting cable complete with connectors, between IOB 49 and ND 780
ID 532889-xx

Distribution cable complete with connectors, for simultaneous connection of the IOB 49 and the KT 130 to the ND 780
ID 532909-01

The additional functions can be configured on the ND 780 when the IOB 49 is connected.

	IOB 49
4 switching inputs	Zero reset of axes 1 to 3 (for milling applications) Recognition of max. 3 operating gears (for turning applications) External activation of CSS (for turning applications)
9 switching outputs	8 relay outputs as switching functions (for milling applications) 1 relay output for readiness
1 analog output	0 to 10 V (turning mode) for constant surface speed
Power supply	Via ND 780
Cable length	≤ 15 m to the ND 780
Storage temperature	-20 °C to +70 °C
Operating temperature	0 °C to 45 °C

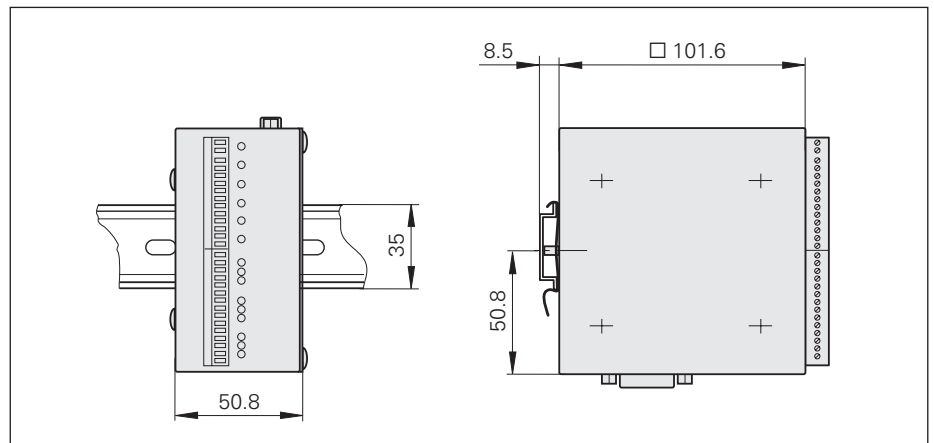

Switching inputs

The switching inputs are active when a High signal (contact or pulse) is present. They are isolated and can be supplied externally or internally.

Signal level of the switching outputs

$$0\text{ V} \leq U_L \leq 1.5\text{ V}$$

$$4.5\text{ V} \leq U_H \leq 26\text{ V}$$

$$I_L \leq 25\text{ mA}$$

$$t_{\min} \geq 100\text{ ms}$$

Zero reset

In the milling mode, each axis can be set to the display value 0 over an external signal.

Detection of gear ranges

In the turning mode, three switching inputs are available for the recognition of gear ranges.

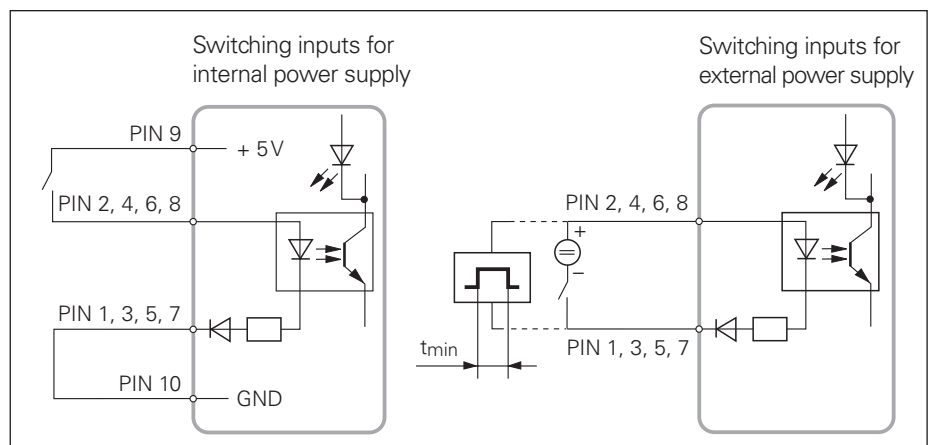

Switching outputs

The IOB 49 features nine floating relay outputs.

Readiness

The readiness output is at LOW level when the ND 780 cannot operate the IOB (e.g. not switched on, cable disconnected).

Switching functions (milling applications)

One or more switching ranges or switching points can be defined for an axis. The **switch-off ranges** are located symmetrically around the display value 0. If **switching points** are used, the relay activates when the position display reaches a specific value. The **direction** function switches when the algebraic sign is changed.

You can set whether

- the switching function should apply to the actual value or distance-to-go mode
- the relay will open or close when the condition is met
- or the relay remains activated as long as the switching condition is met (continuous mode) or for a specified duration (pulsed mode).

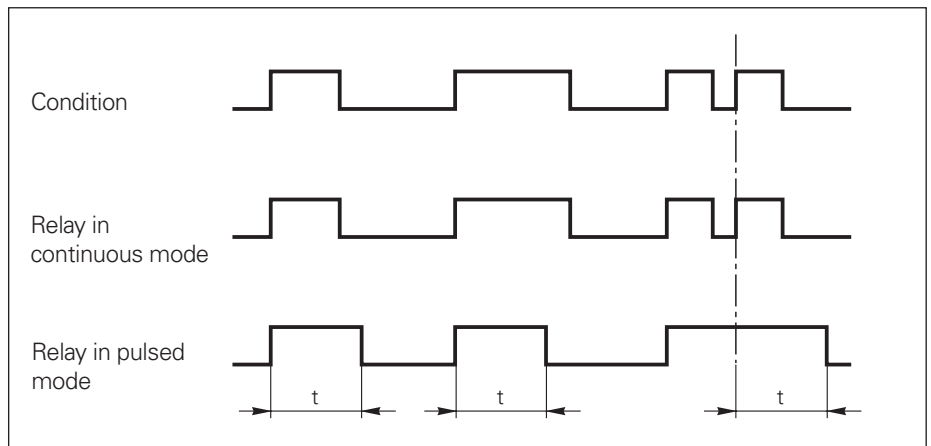
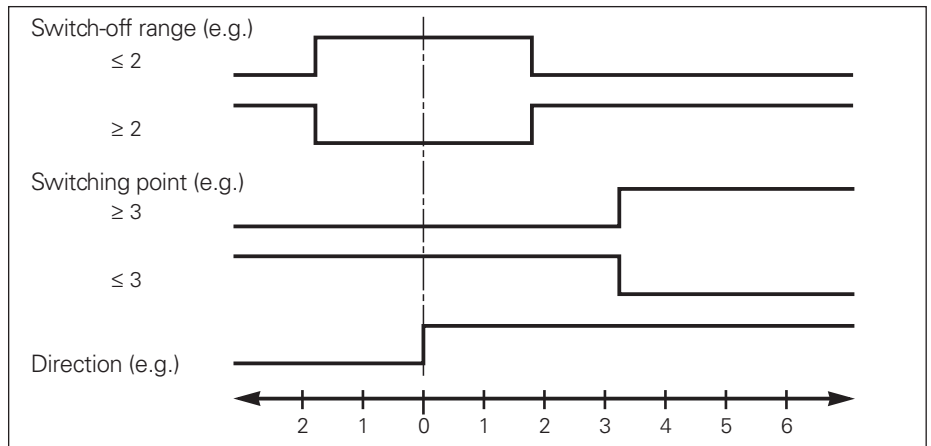
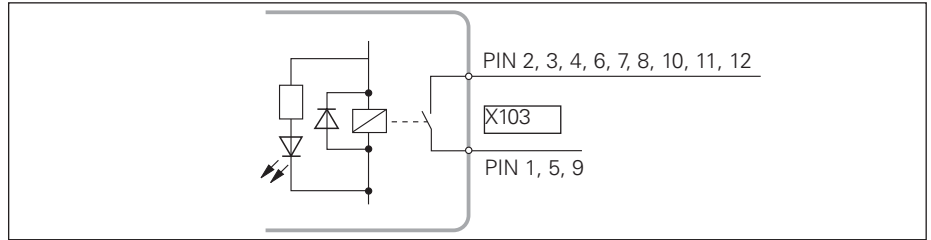

Analog output

Constant surface cutting speed CSS

(turning applications)

The CSS functionality provides spindle speed control as the diameter of the workpiece changes. A speed command signal is sent to the inverter of the spindle motor via the analog interface (DAC 0 to 10 V) of the IOB 49. The maximum and minimum permissible spindle speeds can be specified. In addition, a maximum of three operating gears can be taken into account. The ND 780 recognizes the current gear selection by means of the switching inputs of the IOB 49. CSS control can also be started remotely (via an input to the CSS board) with an external switch.

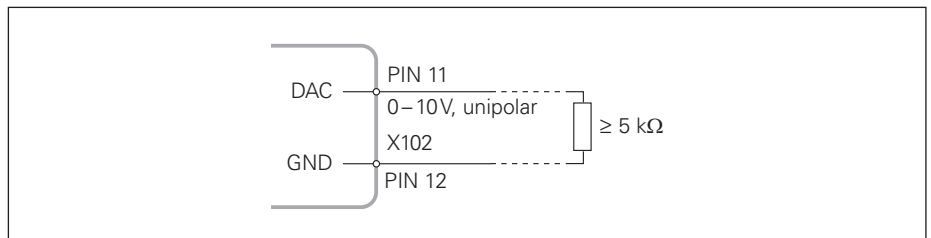

Interfaces

– Switching I/O on POSITIP 880 over IOB 89

The POSITIP 880 features switching functions that you can define as desired. The IOB 89 external input/output unit is necessary to output the switching signals.

IOB 89 external input/output unit ID 532884-01

The IOB 89 input/output unit is attached to a standard NS 35 rail (EN 50022 or DIN 46227). It is connected to the POSITIP 880 via the AMI (auxiliary machining interface). LEDs show the status of the inputs and outputs.

Accessories:

Connecting cable complete with connector, between IOB 89 and POSITIP 880
ID 532856-xx

	IOB 89
8 switching inputs	<ul style="list-style-type: none"> • Zero axes 1 to 6 • Start data output (contact or pulse)
9 switching outputs	8 freely definable switching functions 1 switching output ready for POSITIP 880
Power supply	<i>Device:</i> 24 V - ± 20 %/max. 1 A <i>Inputs:</i> 5 V or 24 V - ± 20 %/min. 0.25 A
Cable length	Max. 10 m to POSITIP 880
Storage temperature Operating temperature	-20 °C to +70 °C 0 °C to 45 °C

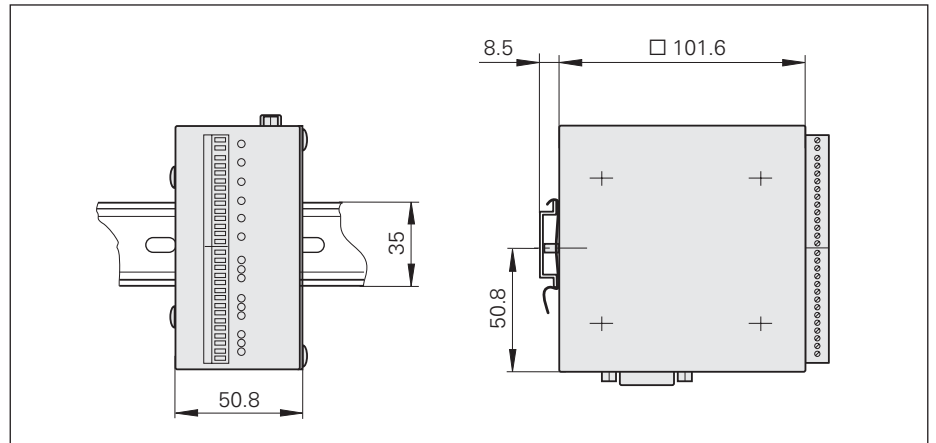

Switching inputs

All switching inputs respond either to contact or pulse.

Exception: The switching inputs for transmitting measured values over the data interface are separate for contact and pulse.

The switching input E is active when a Low signal U_L is applied (contact or pulse to 0V).

Signal level

- $0.5V \leq U_L \leq 0.9V$ at $I_L \leq 6\text{ mA}$
- $3.9V \leq U_H \leq 15.0V$
- $t_{min} \geq 30\text{ ms}$

Zero reset

Each axis can be set to the display value 0 over an external signal.

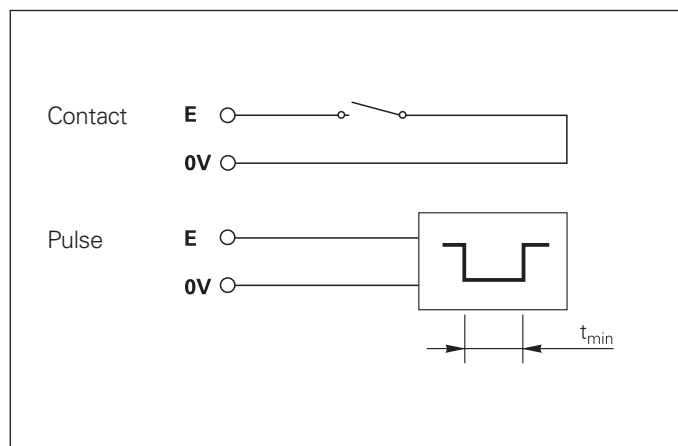

Switching outputs

Signal level of the switching outputs

$U_L \leq 1.5\text{ V}$ at $I_L \leq 100\text{ mA}$
 $U_H \leq 24\text{ V}$ at $I_H \leq 0.3\text{ mA}$

Delay until signal output

$t_D \leq 10\text{ ms}$

Readiness

This permanently available output is at LOW level when the POSITIP 880 cannot control the die IOB (e.g. IOB is not switched on, cable is disconnected).

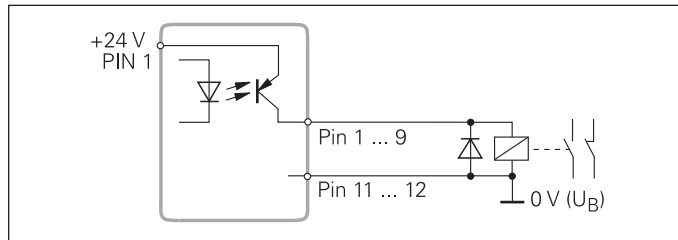

Switching I/O functions

The switching outputs can be configured on the POSITIP 880 when the IOB 89 is connected, and assigned to any axes. The following functions are possible:

Output of the traverse direction

The output switches with each change of the direction of traverse.

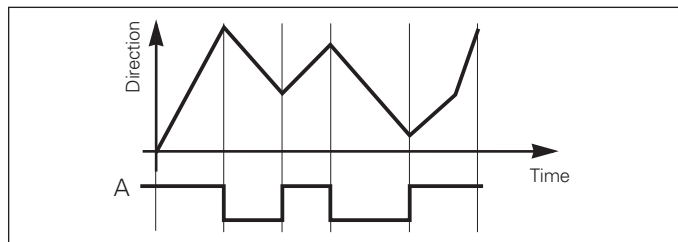

Switch-off ranges

The switch-off ranges are located symmetrically around the display value 0. They can be assigned to the axes in any manner. In the distance-to-go display mode (traverse to 0), switch-off signals are generated for any target position.

Trigger points

The output switches at the programmed position. The algebraic sign is taken into account.

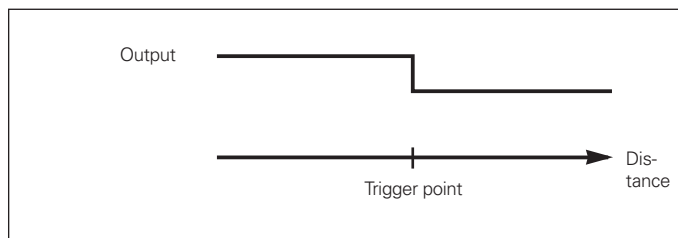
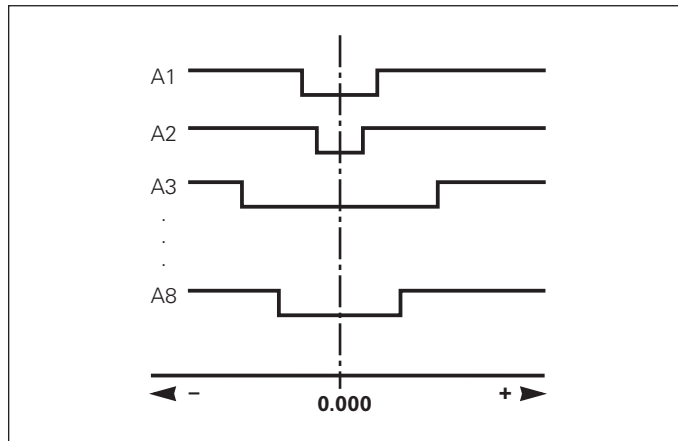

Cable Overview

– ND 28x, ND 52x

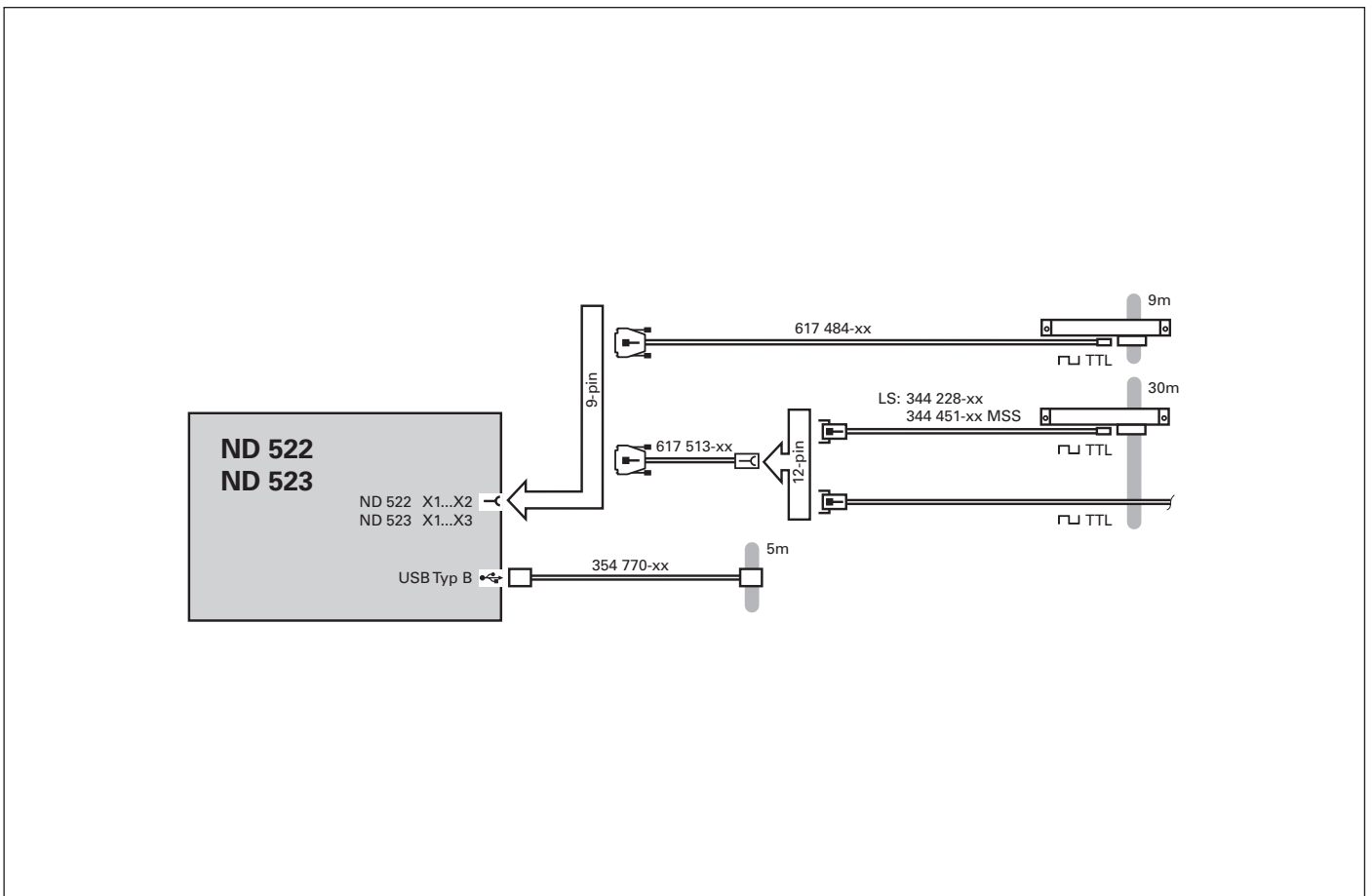
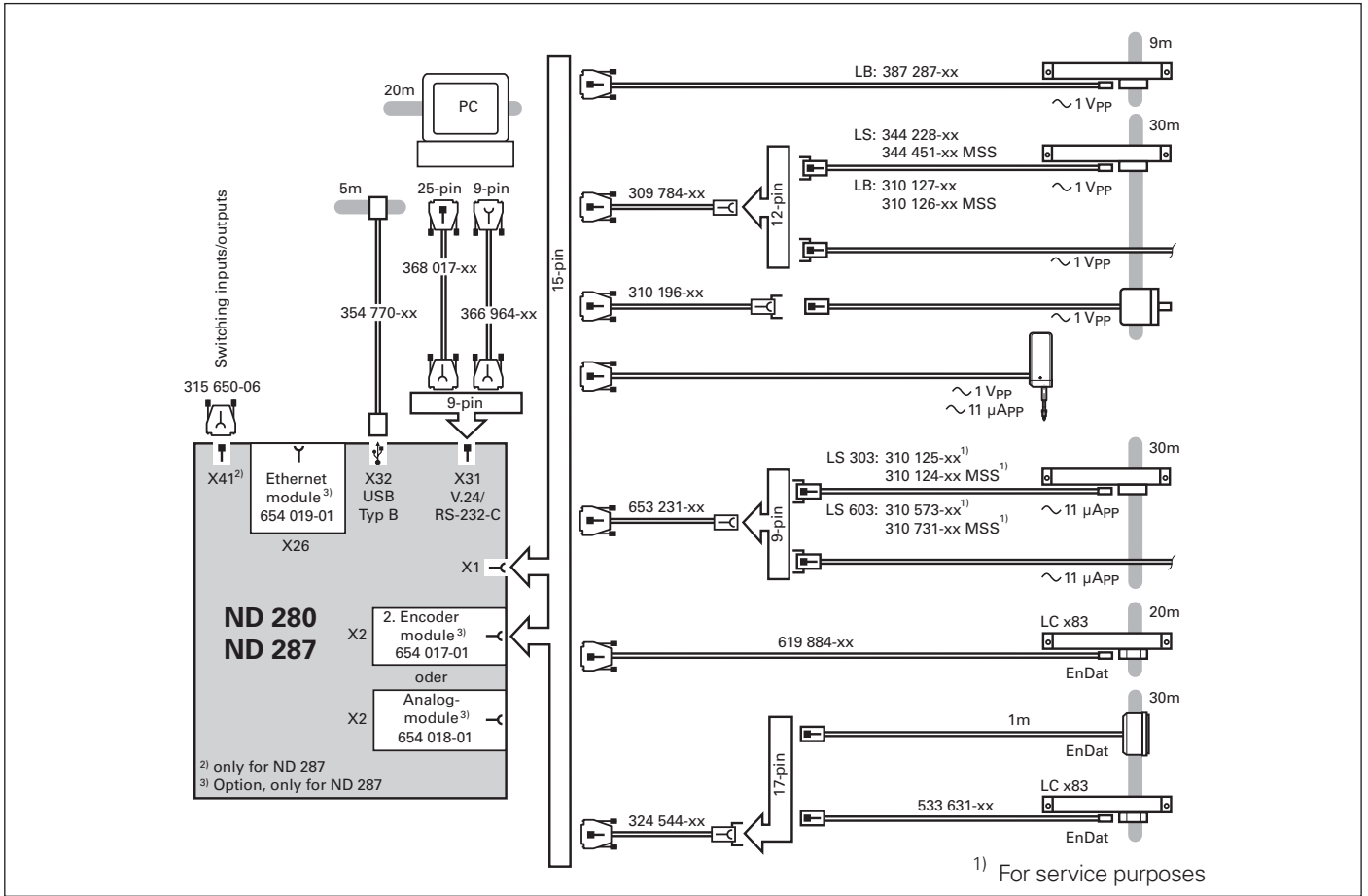

Linear Encoders

– for Manually Operated Machine Tools

For typical applications on manual machine tools such as milling machines or lathes **display steps of 10 µm or 5 µm** are sufficient.

Such display steps are provided by the LS 300 and LS 600 series linear encoders with an accuracy grade of $\pm 10 \mu\text{m}$ per meter traverse.

Jig boring machines, grinding machines, and measuring and inspection tasks normally require **display steps of 1 µm** and smaller. Linear encoders for these more stringent requirements typically feature accuracy grades of $\pm 5 \mu\text{m}$ per meter traverse. These linear encoders, such as LS 487 or LS 187, are described in the *Linear Encoders for Numerically Controlled Machine Tools* brochure.

For **limited installation space**, for example on the slide of a lathe, the linear encoders may be the best solution.

The linear encoders with full-sized scale housing function as universal linear encoders under **normal mounting conditions**.

Linear encoders for large traverses

On large boring or milling machines, but also on lathes with long Z axes, traverse ranges can extend three meters and more. HEIDENHAIN has the proper linear encoders for such special applications.

The **LB 382** with full-sized scale housing makes **measuring lengths of up to 30040 mm** possible. The housing is assembled from sections and mounted on the machine, and the single steel scale tape is then pulled into its slot. The LB 382 is described in the *Linear Encoders for Numerically Controlled Machine Tools* brochure.

Absolute Linear Encoders

Encoders for absolute position measurement are used on machines and equipment where axis positions must already be known upon switch-on. The LC 483 and LC 183 absolute linear encoders are described in the *Linear Encoders for Numerically Controlled Machine Tools* brochure.

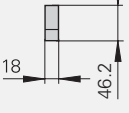
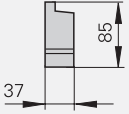
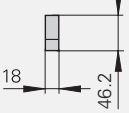
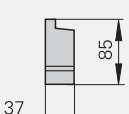
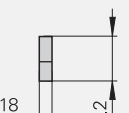
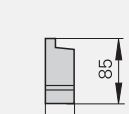
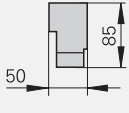
	Scale housing	Accuracy grade	Measuring lengths
Recommended measuring steps 10 µm, 5 µm			
Incremental linear measurement • Glass scale	Slimline 	$\pm 10 \mu\text{m}$	70 mm to 1240 mm
	Full size 	$\pm 10 \mu\text{m}$	140 mm to 3040 mm
Recommended measuring steps 1 µm, 0.5 µm and finer			
Incremental linear measurement • Glass scale	Slimline 	$\pm 5 \mu\text{m}$ $\pm 3 \mu\text{m}$	70 to 1240 mm <i>With mounting spar:</i> 70 mm to 2040 mm
	Full size 	$\pm 5 \mu\text{m}$ $\pm 3 \mu\text{m}$	140 mm to 3040 mm
Absolute linear measurement • Glass scale	Slimline 	$\pm 5 \mu\text{m}$ $\pm 3 \mu\text{m}$	70 to 1240 mm <i>With mounting spar or clamping elements:</i> 70 mm to 2040 mm
	Full size 	$\pm 5 \mu\text{m}$ $\pm 3 \mu\text{m}$	140 mm to 3040 mm
Recommended measuring steps 10 µm, 5 µm, 1 µm			
Incremental linear measurement for large measuring lengths • Steel scale tape	Full size 	$\pm 5 \mu\text{m}$	440 mm to 30040 mm



LB 382

	Incremental signals/ Signal period	Absolute position values	Model	For more information
	\sim 1 V _{PP} 20 μm	–	LS 388C	Page 46
	\square TTL, 20 μm		LS 328C	
	\sim 1 V _{PP} 20 μm		LS 688C	Page 48
	\square TTL, 20 μm		LS 628C	
	\sim 1 V _{PP} 20 μm	–	LS 487	Catalog <i>Linear Encoders for Numerically Controlled Machine Tools</i>
	\square TTL, To 1 μm		LS 477	
	\sim 1 V _{PP} 20 μm		LS 187	
	\square TTL, To 1 μm		LS 177	
	\sim 1 V _{PP} 20 μm	EnDat 2.2	LC 483	
	\sim 1 V _{PP} 20 μm	EnDat 2.2	LC 183	
	\sim 1 V _{PP} 40 μm	EnDat 2.2	LB 382	Catalog <i>Linear Encoders for Numerically Controlled Machine Tools</i>



LS 388C



LS 628C



LS 487



LC 483



LS 187/LC 183



Mounting Information

– Slimline Linear Encoders

LS 300 Series

The slimline linear encoders should be fastened over their entire length onto a machined surface. The encoder is mounted so that the sealing lips are directed downward or away from splashwater.

Mounting

It is surprisingly simple to mount the LS 300 sealed linear encoders: you need only align the scale unit at several points along the machine guideway. Stop surfaces or stop pins can also be used to align the scale.

Use the mounting gauge to easily and quickly set the gap between the scale housing and the scanning unit. You must also ensure that the lateral tolerance is maintained.

Accessories

Mounting gauge

ID 528 753-01

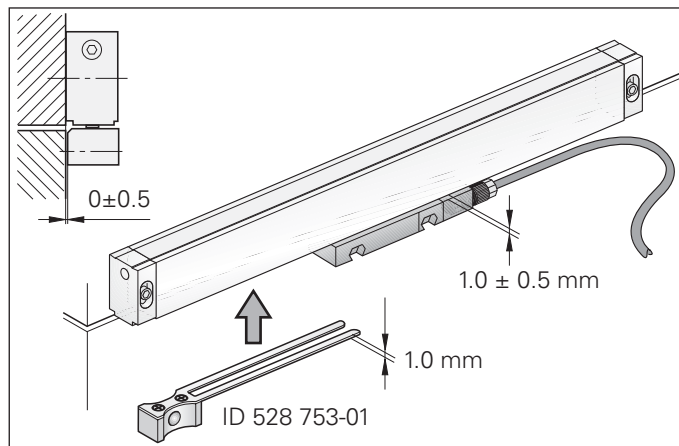
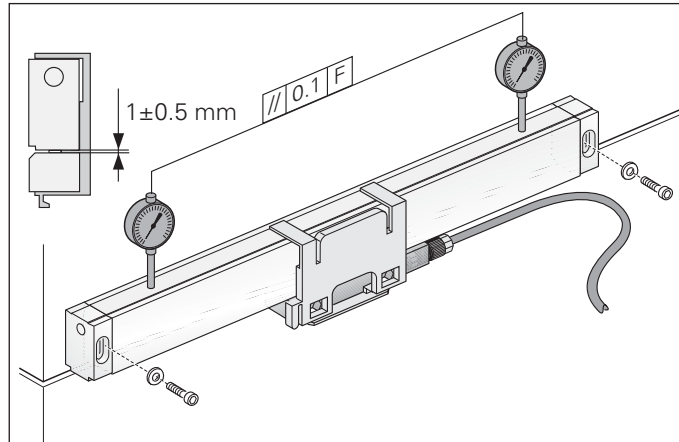

– Full-Size Linear Encoders

LS 600 Series

The full-size linear encoders are fastened to a machined surface only at the ends with their mounting blocks. Measuring lengths over 620 mm require support brackets to improve vibration behavior.

The inclined arrangement of the sealing lips permits universal mounting with vertical or horizontal scale housing with equally high protection rating.

Mounting

When mounting the LS 600, the shipping brace already sets the proper gap between the scale unit and the scanning unit. You need only align the scale unit at several points along the machine guideway.

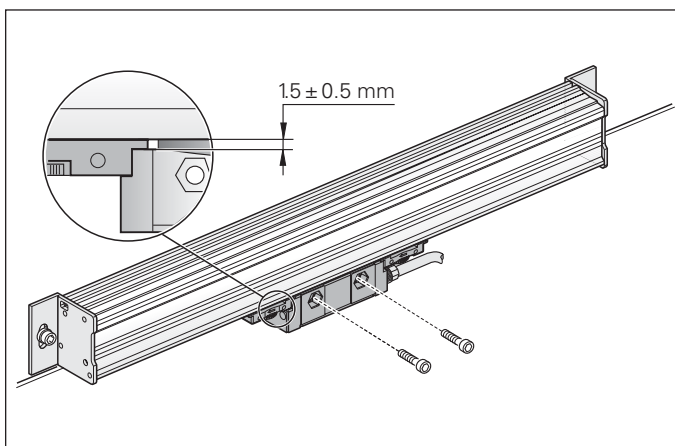
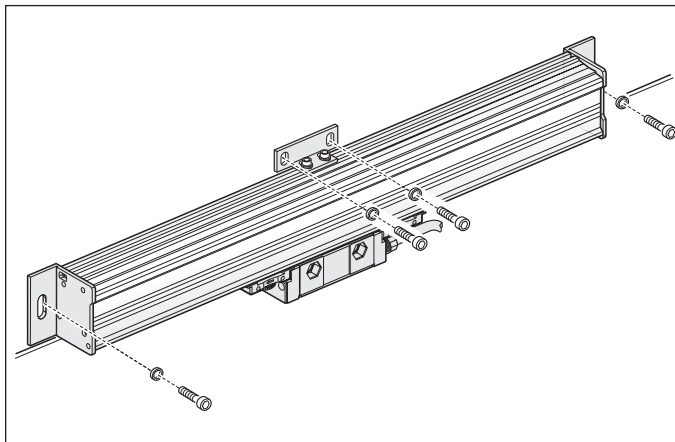

LS 300 Series

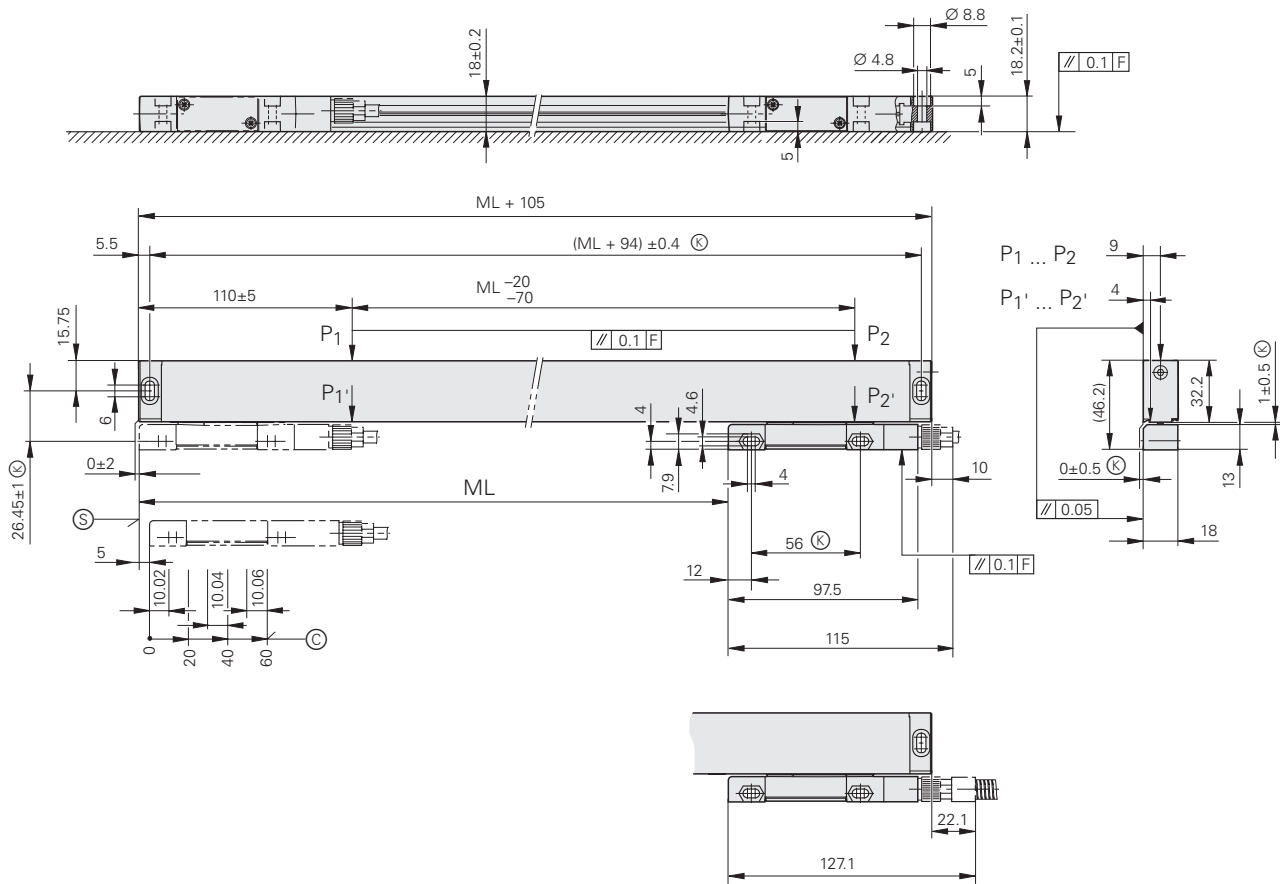

Dimensions in mm



Tolerancing ISO 8015

ISO 2768 - m H

< 6 mm: ± 0.2 mm

Ⓢ = Beginning of measuring length (ML)

ⓐ = Reference mark position

F = Machine guideway

P = Gauging points for alignment

Ⓚ = Required mating dimensions



Specifications	Incremental	
	LS 388C	LS 328C
Measuring standard	Glass scale with DIADUR graduation	
Accuracy grade	± 10 µm	
Measuring length ML*	70 120 170 220 270 320 370 420 470 520 570 620 670 720 770 820 870 920 970 1020 1140 1240	
Incremental signals	~ 1 V _{pp}	□ TTL
Grating period	20 µm	
Edge separation a	–	≤ 5 µs
Reference mark	Distance-coded	
Recommended measuring step¹⁾	10 µm, 5 µm	
Power supply	5 V ± 5% / < 100 mA (without load)	
Electrical connection	Separate adapter cable connectable to mounting block	
Cable length	≤ 30 m (with HEIDENHAIN cable)	
Traversing speed	≤ 60 m/min	
Required moving force	≤ 5 N	
Vibration 55 to 2000 Hz Shock 6 ms	≤ 150 m/s ² (EN 60068-2-6) ≤ 300 m/s ² (EN 60068-2-27)	
Operating temperature	0 °C to 50 °C	
Protection EN 60529	IP 53 when mounted according to the instructions	
Weight	0.27 kg + 0.67 kg/m measuring length	

* Please select when ordering

¹⁾ For position measurement

LS 600 Series

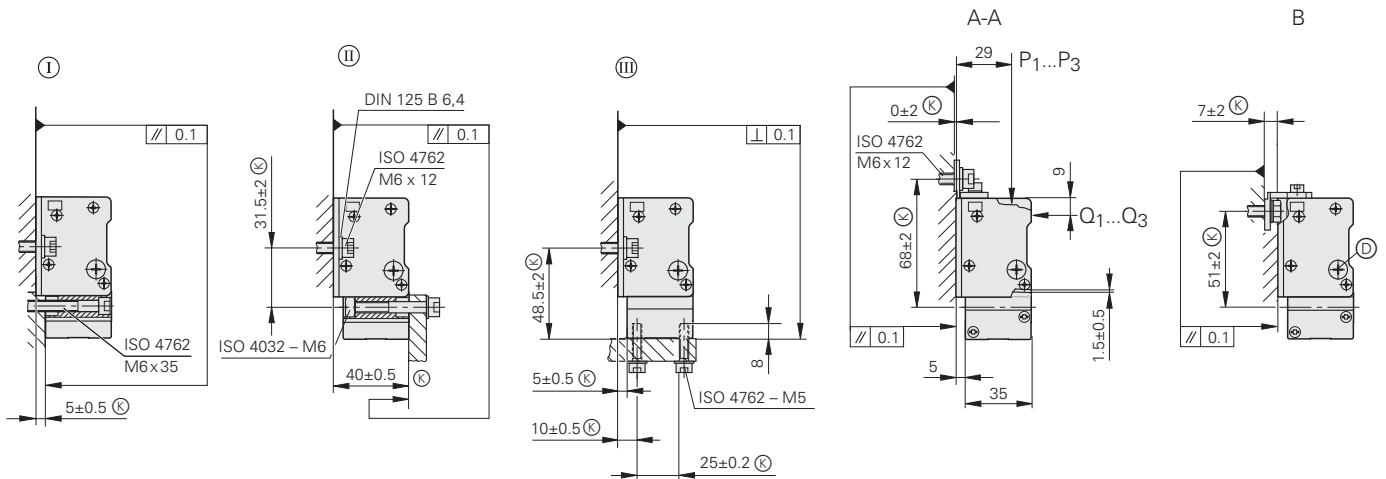
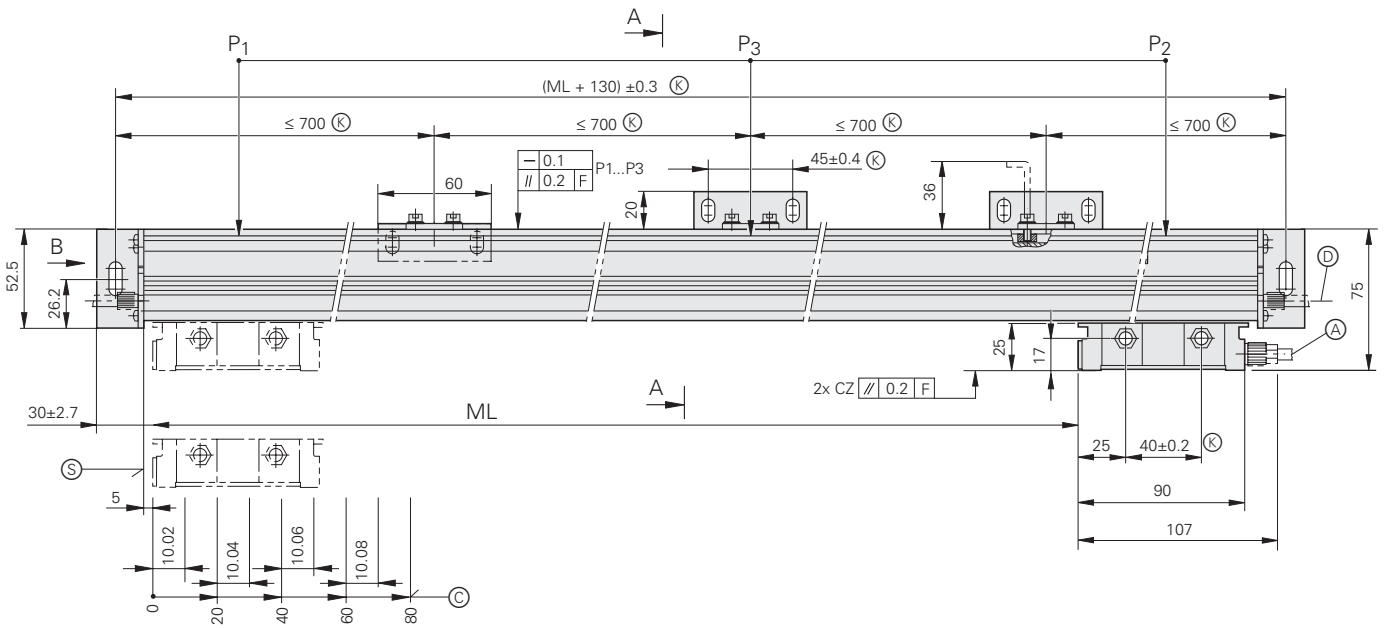
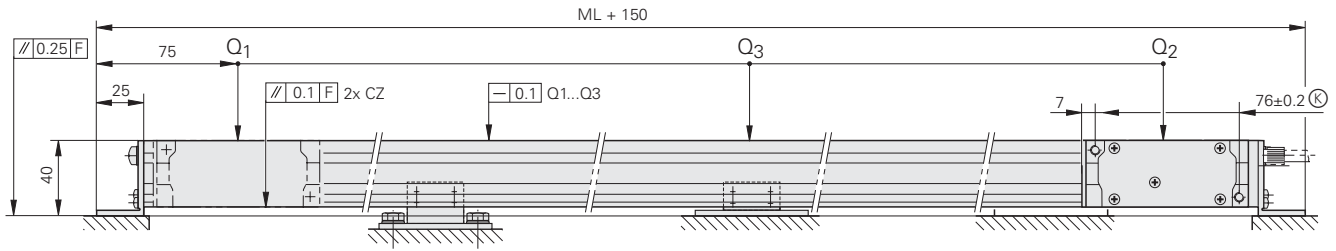

Dimensions in mm



Tolerancing ISO 8015
ISO 2768 - m H
< 6 mm: ±0.2 mm

ⓐ, ⓑ,

ⓓ = Mounting options

F = Machine guideway

P, Q = Gauging points for alignment

Ⓐ = Cable connection usable at either end

ⓑ = Compressed air inlet usable at either end

Ⓚ = Required mating dimensions

Ⓢ = Beginning of measuring length (ML)

Ⓒ = Reference-mark position on LS 6x8C



Specifications	Incremental	
	LS 688C	LS 628C
Measuring standard	Glass scale with DIADUR graduation	
Accuracy grade	± 10 µm	
Measuring length ML*	170 220 270 320 370 420 470 570 620 720 770 820 920 1020 1140 1240 1340 1440 1540 1640 1740 1840 2040 2240 2440 2640 2840 3040	
Incremental signals	~ 1 V _{PP}	□□ TTL
Grating period	20 µm	
Edge separation a	–	≤ 5 µs
Reference mark	Distance-coded	
Recommended measuring step¹⁾	10 µm, 5 µm	
Power supply	5 V ± 5% / < 100 mA (without load)	
Electrical connection	Separate adapter cable connectable to mounting block	
Cable length	≤ 30 m (with HEIDENHAIN cable)	
Traversing speed	≤ 60 m/min	
Required moving force	≤ 5 N	
Vibration 55 to 2000 Hz Shock 6 ms	≤ 150 m/s ² (IEC 60068-2-6) ≤ 300 m/s ² (IEC 60068-2-27)	
Operating temperature	0 °C to 50 °C	
Protection EN 60529	IP 53 when mounted according to the instructions	
Weight	0.7 kg + 2 kg/m measuring length	

* Please select when ordering

¹⁾ For position measurement

Interfaces

– Incremental Signals $\sim 1 V_{PP}$

HEIDENHAIN encoders with $\sim 1 V_{PP}$ interface provide voltage signals that can be highly interpolated.

The sinusoidal **incremental signals** A and B are phase-shifted by 90° elec. and have amplitudes of typically $1 V_{PP}$. The illustrated sequence of output signals—with B lagging A—applies to the direction of motion shown in the dimension drawing.

The **reference mark signal** R has a usable component G of approx. $0.5 V$. Next to the reference mark, the output signal can be reduced by up to $1.7 V$ to a quiescent value H. This must not cause the subsequent electronics to overdrive. Even at the lowered signal level, signal peaks with the amplitude G can also appear.

The data on **signal amplitude** apply when the power supply given in the specifications is connected to the encoder. They refer to a differential measurement at the 120 ohm terminating resistor between the associated outputs. The signal amplitude decreases with increasing frequency. The **cutoff frequency** indicates the scanning frequency at which a certain percentage of the original signal amplitude is maintained:

- $-3 \text{ dB} \triangleq 70 \%$ of the signal amplitude
- $-6 \text{ dB} \triangleq 50 \%$ of the signal amplitude

The data in the signal description apply to motions at up to 20% of the -3 dB cutoff frequency.

Interpolation/resolution/measuring step

The output signals of the $1 V_{PP}$ interface are usually interpolated in the subsequent electronics in order to attain sufficiently high resolutions. For **velocity control**, interpolation factors are commonly over 1000 in order to receive usable velocity information even at low speeds.

Measuring steps for **position measurement** are recommended in the specifications. For special applications, other resolutions are also possible.

Short-circuit stability

A temporary short circuit of one signal output to $0 V$ or U_P (except encoders with $U_{Pmin} = 3.6 V$) does not cause encoder failure, but it is not a permissible operating condition.

Short circuit at	$20^\circ C$	$125^\circ C$
One output	< 3 min	< 1 min
All outputs	< 20 s	< 5 s

Interface	Sinusoidal voltage signals $\sim 1 V_{PP}$
Incremental signals	2 nearly sinusoidal signals A and B Signal amplitude M: 0.6 to $1.2 V_{PP}$; typically $1 V_{PP}$ Asymmetry $ P - N /2M$: ≤ 0.065 Signal ratio M_A/M_B : 0.8 to 1.25 Phase angle $ \varphi_1 + \varphi_2 /2$: $90^\circ \pm 10^\circ$ elec.
Reference mark signal	One or more signal peaks R Usable component G: $\geq 0.2 V$ Quiescent value H: $\leq 1.7 V$ Switching threshold E, F: 0.04 to $0.68 V$ Zero crossovers K, L: $180^\circ \pm 90^\circ$ elec.
Connecting cable	Shielded HEIDENHAIN cable PUR $[4(2 \times 0.14 \text{ mm}^2) + (4 \times 0.5 \text{ mm}^2)]$ Max. 150 m at 90 pF/m distributed capacitance Propagation time 6 ns/m

These values can be used for dimensioning of the subsequent electronics. Any limited tolerances in the encoders are listed in the specifications. For encoders without integral bearing, reduced tolerances are recommended for initial servicing (see the mounting instructions).

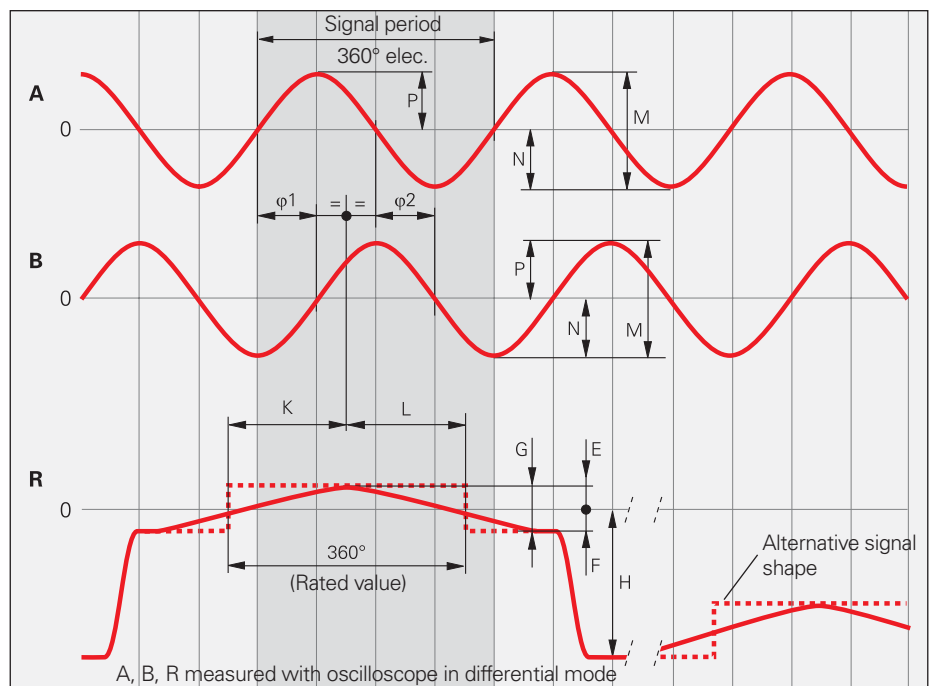

Cutoff frequency

Typical signal amplitude curve with respect to the scanning frequency

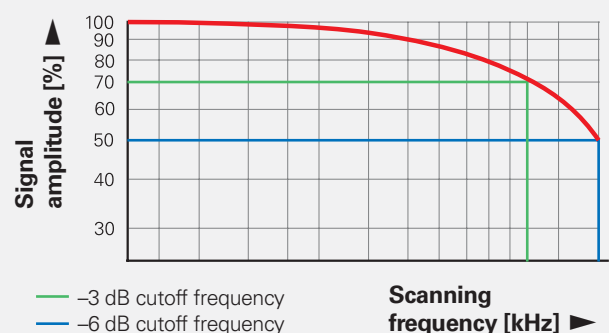

Input circuitry of the subsequent electronics

Dimensioning

Operational amplifier MC 34074

$Z_0 = 120 \Omega$

$R_1 = 10 \text{ k}\Omega$ and $C_1 = 100 \text{ pF}$

$R_2 = 34.8 \text{ k}\Omega$ and $C_2 = 10 \text{ pF}$

$U_B = \pm 15 \text{ V}$

U_1 approx. U_0

-3dB cutoff frequency of circuitry

Approx. 450 kHz

Approx. 50 kHz and $C_1 = 1000 \text{ pF}$
and $C_2 = 82 \text{ pF}$

The circuit variant for 50 kHz does reduce the bandwidth of the circuit, but in doing so it improves its noise immunity.

Circuit output signals

$U_a = 3.48 V_{PP}$ typical

Gain 3.48

Monitoring of the incremental signals

The following thresholds are recommended for monitoring of the signal level M:

Lower threshold: 0.30 V_{PP}

Upper threshold: 1.35 V_{PP}

Incremental signals Reference mark signal

$R_a < 100 \Omega$,
typically 24Ω
 $C_a < 50 \text{ pF}$
 $\Sigma I_a < 1 \text{ mA}$
 $U_0 = 2.5 \text{ V} \pm 0.5 \text{ V}$
(relative to 0V of the power supply)

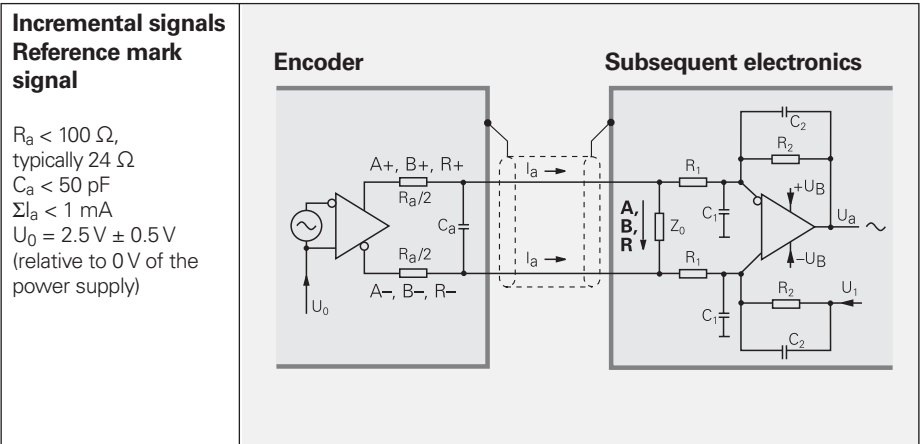

LS 388 C, LS 688 C pin layout

12-pin M23 coupling (male)				12-pin M23 connector (male)									
15-pin D-sub connector (female)				15-pin D-sub connector (male)									
For ND 780, POSITIP, IK 220				For ND 28x									
	Power supply			Incremental signals						Other signals			
	12	2	10	11	5	6	8	1	3	4	9	7	/
	1	9	2	11	3	4	6	7	10	12	5/8/13/15	14	-
	4	12	2	10	1	9	3	11	14	7	5/6/8/15	13	/
	Up	Sensor U_p	0V	Sensor 0V	A+	A-	B+	B-	R+	R-	Vacant	Vacant	Vacant
	Brown/ Green	Blue	White/ Green	White	Brown	Green	Gray	Pink	Red	Black	/	Violet	Yellow

Shield on housing; **Up** = power supply voltage

Sensor: The sensor line is connected internally with the corresponding power line.

Vacant pins or wires must not be used!

Interfaces

– Incremental Signals \square TTL

HEIDENHAIN encoders with \square TTL interface incorporate electronics that digitize sinusoidal scanning signals with or without interpolation.

The **incremental signals** are transmitted as the square-wave pulse trains U_{a1} and U_{a2} , phase-shifted by 90° elec. The **reference mark signal** consists of one or more reference pulses U_{a0} , which are gated with the incremental signals. In addition, the integrated electronics produce their **inverse signals** $\overline{U_{a1}}$, $\overline{U_{a2}}$ and $\overline{U_{a0}}$ for noise-proof transmission. The illustrated sequence of output signals—with U_{a2} lagging U_{a1} —applies to the direction of motion shown in the dimension drawing.

The **fault-detection signal** $\overline{U_{aS}}$ indicates fault conditions such as breakage of the power line or failure of the light source. It can be used for such purposes as machine shut-off during automated production.

The distance between two successive edges of the incremental signals U_{a1} and U_{a2} through 1-fold, 2-fold or 4-fold evaluation is one **measuring step**.

The subsequent electronics must be designed to detect each edge of the square-wave pulse. The minimum **edge separation a** listed in the *Specifications* applies to the illustrated input circuitry with a cable length of 1 m, and refers to a measurement at the output of the differential line receiver. Cable-dependent differences in the propagation times additionally reduce the edge separation by 0.2 ns per meter of cable. To prevent counting errors, design the subsequent electronics to process as little as 90% of the resulting edge separation. The max. permissible **shaft speed** or **traversing velocity** must never be exceeded.

The permissible **cable length** for transmission of the TTL square-wave signals to the subsequent electronics depends on the edge separation a . It is 100 m or 50 m max. for the fault detection signal. This requires, however, that the power supply (see *Specifications*) be ensured at the encoder. The sensor lines can be used to measure the voltage at the encoder and, if required, correct it with a closed-loop system (remote sense power supply).

Interface	Square-wave signals \square TTL
Incremental signals	2 TTL square-wave signals U_{a1}, U_{a2} and their inverted signals $\overline{U_{a1}}$, $\overline{U_{a2}}$
Reference mark signal Pulse width Delay time	1 or more TTL square-wave pulses U_{a0} and their inverted pulses $\overline{U_{a0}}$ 90° elec. (other widths available on request); LS 323: ungated $ t_d \leq 50$ ns
Fault-detection signal Pulse width	1 TTL square-wave pulse $\overline{U_{aS}}$ Improper function: LOW (upon request: U_{a1}/U_{a2} high impedance) Proper function: HIGH $t_S \geq 20$ ms
Signal level	Differential line driver as per EIA standard RS 422 $U_H \geq 2.5$ V at $-I_H = 20$ mA $U_L \leq 0.5$ V at $I_L = 20$ mA
Permissible load	$Z_0 \geq 100 \Omega$ between associated outputs $ I_L \leq 20$ mA max. load per output $C_{load} \leq 1000$ pF with respect to 0 V Outputs protected against short circuit to 0 V
Switching times (10 % to 90 %)	$t_r / t_f \leq 30$ ns (typically 10 ns) with 1 m cable and recommended input circuitry
Connecting cable Cable length Propagation time	Shielded HEIDENHAIN cable PUR [$4(2 \times 0.14 \text{ mm}^2) + (4 \times 0.5 \text{ mm}^2)$] Max. 100 m ($\overline{U_{aS}}$ max. 50 m) at 90 pF/m distributed capacitance 6 ns/m

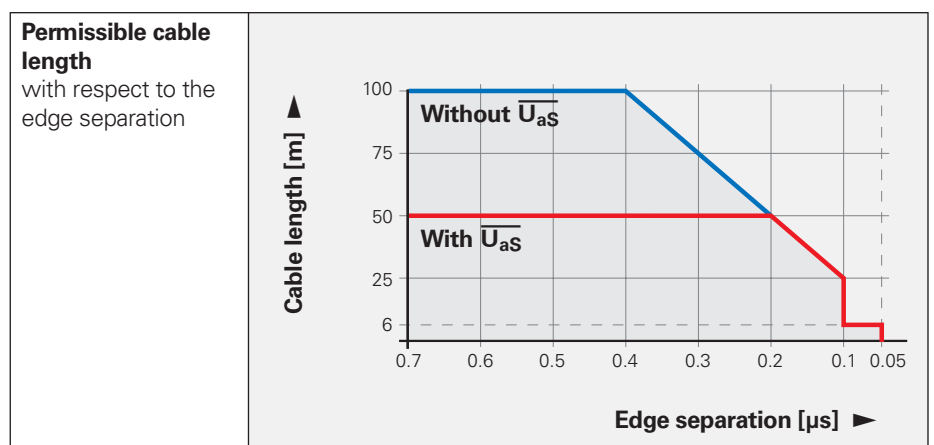
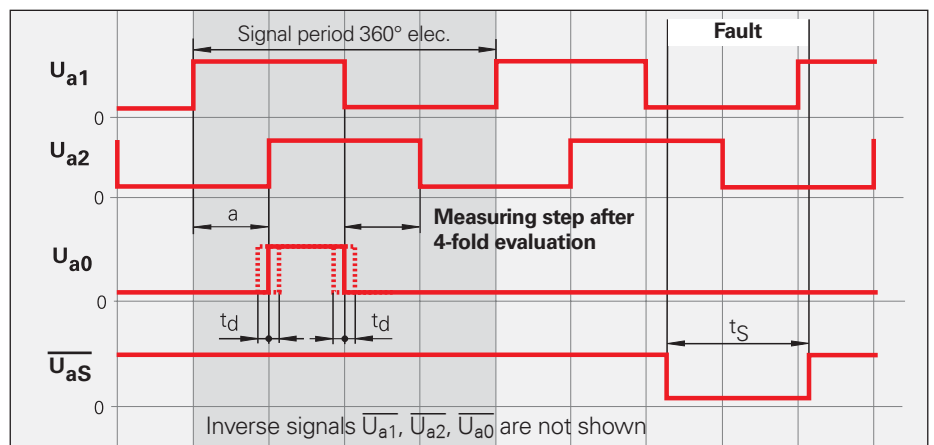

Input circuitry of the subsequent electronics

Dimensioning

IC₁ = Recommended differential line receivers
 DS 26 C 32 AT
 Only for a > 0.1 μs:
 AM 26 LS 32
 MC 3486
 SN 75 ALS 193

R₁ = 4:7 kΩ
 R₂ = 1.8 kΩ
 Z₀ = 120 Ω
 C₁ = 220 pF (serves to improve noise immunity)

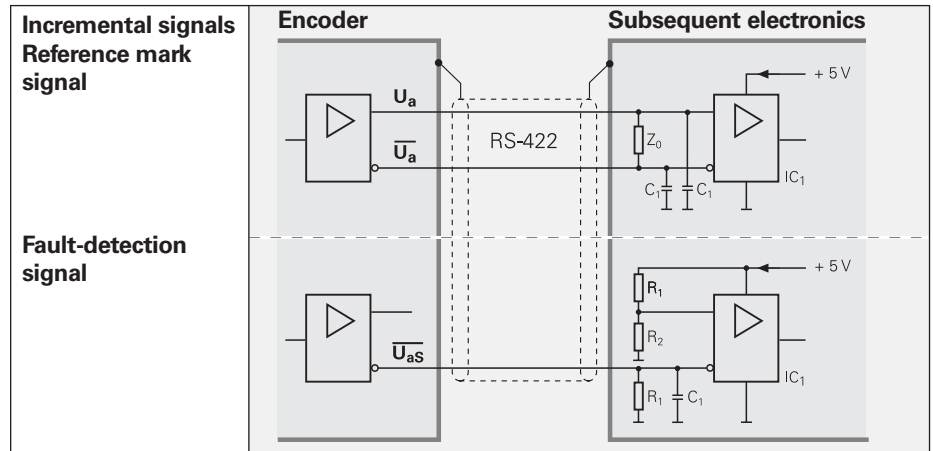

LS 328 C, LS 628 C pin layout

12-pin M23 coupling, (male) 													
9-pin D-sub connector, (male) For ND 52x													
	Power supply	Incremental signals	Other signals										
	12	2	10	11	5	6	8	1	3	4	7	/	9
	7	/	6	/	2	3	4	5	9	8	/	1	/
	U _P	Sensor U _P	0V	Sensor 0V	U _{a1}	U _{a1}	U _{a2}	U _{a2}	U _{a0}	U _{a0}	U _{aS}	Vacant	Vacant
	Brown/Green	Blue	White/Green	White	Brown	Green	Gray	Pink	Red	Black	Violet	/	Yellow







Cable shield connected to housing; **U_P** = power supply voltage

Sensor: The sensor line is connected internally with the corresponding power line.

Vacant pins or wires must not be used!







Electrical Connection

Connecting Elements and Cables

Adapter cables		LS 388C LS 688C	LS 328C LS 628C
Adapter cable with M23 connector (male), 12-pin Extension cable Ø 6 mm		344 228-xx	
Armored adapter cable with M23 connector (male), 12-pin Extension cable Ø 10 mm		344 451-xx	
Adapter cable with D-sub connector, (male) 0.15-pin Cable for ND 28x Ø 6 mm		387 287-xx	–
Adapter cable with braiding With D-sub connector (male) 9-pin Cable for ND 52x Ø 6 mm		–	617 484-xx ¹⁾
Adapter cable with D-sub connector, (female) 15-pin Cable for ND 780 and PT 880 Ø 6 mm		360 974-xx	–
Armored adapter cable with D-sub connector (female), 15-pin Cable for ND 780 and PT 880 Ø 10 mm		539 878-xx	–

Available cable lengths: 1 m/3 m/6 m/9 m

¹⁾ Max. cable length 6 m

PUR connecting cable Ø 8 mm 12-pin: [4(2 x 0.14 mm ²) + (4 x 0.5 mm ²)]		LS 388C LS 688C	LS 328C LS 628C
Complete For extension with M23 coupling (female), 12-pin and M23 connector (male), 12-pin		298 400-xx	
Complete For ND 28x with M23 coupling (female), 12-pin and D-sub connector (male), 15-pin		309 784-xx	
With one connector For ND 52x with M23 coupling (female), 12-pin and D-sub connector (male), 9-pin		–	617 484-xx
Complete For ND 780, POSITIP 880 with M23 coupling (female), 12-pin and D-sub connector (male), 15-pin		309 783-xx	–
With one connector With M23 coupling (female), 12-pin		298 402-xx	
Cable only		244 957-01	

HEIDENHAIN

DR. JOHANNES HEIDENHAIN GmbH

Dr.-Johannes-Heidenhain-Straße 5

83301 Traunreut, Germany

☎ +49 (8669) 31-0

FAX +49 (8669) 5061

E-Mail: info@heidenhain.de

www.heidenhain.de

DE HEIDENHAIN Technisches Büro Nord

12681 Berlin, Deutschland

☎ (030) 54705-240

E-Mail: tbn@heidenhain.de

HEIDENHAIN Technisches Büro Mitte

08468 Heinsdorfergrund, Deutschland

☎ (03765) 69544

E-Mail: tbm@heidenhain.de

HEIDENHAIN Technisches Büro West

44379 Dortmund, Deutschland

☎ (0231) 618083-0

E-Mail: tbw@heidenhain.de

HEIDENHAIN Technisches Büro Südwest

70771 Leinfelden-Echterdingen, Deutschland

☎ (0711) 993395-0

E-Mail: tbsw@heidenhain.de

HEIDENHAIN Technisches Büro Südost

83301 Traunreut, Deutschland

☎ (08669) 31-1345

E-Mail: tbs0@heidenhain.de

AR NAKASE SRL.

B1653AOX Villa Ballester, Argentina

☎ +54 (11) 47684242

E-Mail: nakase@nakase.com

AT HEIDENHAIN Techn. Büro Österreich

83301 Traunreut, Germany

☎ +49 (8669) 31-1337

E-Mail: tba@heidenhain.de

AU FCR Motion Technology Pty. Ltd

Laverton North 3026, Australia

☎ +61 (3) 93626800

E-Mail: vicsales@fcrmotion.com

BE HEIDENHAIN NV/SA

1760 Roosdaal, Belgium

☎ +32 (54) 343158

E-Mail: sales@heidenhain.be

BG ESD Bulgaria Ltd.

Sofia 1172, Bulgaria

☎ +359 (2) 9632949

E-Mail: info@esd.bg

BR DIADUR Indústria e Comércio Ltda.

04763-070 – São Paulo – SP, Brazil

☎ +55 (11) 5696-6777

E-Mail: diadur@diadur.com.br

BY Belarus → RU

CA HEIDENHAIN CORPORATION

Mississauga, Ontario L5T 2N2, Canada

☎ +1 (905) 670-8900

E-Mail: info@heidenhain.com

CH HEIDENHAIN (SCHWEIZ) AG

8603 Schwerzenbach, Switzerland

☎ +41 (44) 8062727

E-Mail: verkauf@heidenhain.ch

CN DR. JOHANNES HEIDENHAIN

(CHINA) Co., Ltd.

Beijing 101312, China

☎ +86 10-80420000

E-Mail: sales@heidenhain.com.cn

CS Serbia and Montenegro → BG

CZ HEIDENHAIN s.r.o.

106 00 Praha 10, Czech Republic

☎ +420 272658131

E-Mail: heidenhain@heidenhain.cz

DK TP TEKNIK A/S

2670 Greve, Denmark

☎ +45 (70) 100966

E-Mail: tp-gruppen@tp-gruppen.dk

ES FARRESA ELECTRONICA S.A.

08028 Barcelona, Spain

☎ +34 934092491

E-Mail: farresa@farresa.es

FI HEIDENHAIN Scandinavia AB

02770 Espoo, Finland

☎ +358 (9) 8676476

E-Mail: info@heidenhain.fi

FR HEIDENHAIN FRANCE sarl

92310 Sèvres, France

☎ +33 0141143000

E-Mail: info@heidenhain.fr

GB HEIDENHAIN (G.B.) Limited

Burgess Hill RH15 9RD, United Kingdom

☎ +44 (1444) 247711

E-Mail: sales@heidenhain.co.uk

GR MB Milionis Vassilis

17341 Athens, Greece

☎ +30 (210) 9336607

E-Mail: bmilioni@otenet.gr

HK HEIDENHAIN LTD

Kowloon, Hong Kong

☎ +852 27591920

E-Mail: service@heidenhain.com.hk

HR Croatia → SL

HU HEIDENHAIN Kereskedelmi Képviselet

1239 Budapest, Hungary

☎ +36 (1) 4210952

E-Mail: info@heidenhain.hu

ID PT Servitama Era Toolsindo

Jakarta 13930, Indonesia

☎ +62 (21) 46834111

E-Mail: ptset@group.gts.co.id

IL NEUMO VARGUS MARKETING LTD.

Tel Aviv 61570, Israel

☎ +972 (3) 5373275

E-Mail: neumo@neumo-vargus.co.il

IN ASHOK & LAL

Chennai – 600 030, India

☎ +91 (44) 26151289

E-Mail: ashoklal@satyam.net.in

IT HEIDENHAIN ITALIANA S.r.l.

20128 Milano, Italy

☎ +39 02270751

E-Mail: info@heidenhain.it

JP HEIDENHAIN K.K.

Tokyo 102-0073, Japan

☎ +81 (3) 3234-7781

E-Mail: sales@heidenhain.co.jp

KR HEIDENHAIN LTD.

Gasan-Dong, Seoul, Korea 153-782

☎ +82 (2) 2028-7430

E-Mail: info@heidenhain.co.kr

MK Macedonia → BG

MX HEIDENHAIN CORPORATION MEXICO

20235 Aguascalientes, Ags., Mexico

☎ +52 (449) 9130870

E-Mail: info@heidenhain.com

MY ISOSERVE Sdn. Bhd

56100 Kuala Lumpur, Malaysia

☎ +60 (3) 91320685

E-Mail: isoserve@po.jaring.my

NL HEIDENHAIN NEDERLAND B.V.

6716 BM Ede, Netherlands

☎ +31 (318) 581800

E-Mail: verkoop@heidenhain.nl

NO HEIDENHAIN Scandinavia AB

7300 Orkanger, Norway

☎ +47 72480048

E-Mail: info@heidenhain.no

PH Machinebanks Corporation

Quezon City, Philippines 1113

☎ +63 (2) 7113751

E-Mail: info@machinebanks.com

PL APS

02-489 Warszawa, Poland

☎ +48 228639737

E-Mail: aps@apserwis.com.pl

PT FARRESA ELECTRÓNICA, LDA.

4470 - 177 Maia, Portugal

☎ +351 229478140

E-Mail: fep@farresa.pt

RO Romania → HU

RU OOO HEIDENHAIN

125315 Moscow, Russia

☎ +7 (495) 931-9646

E-Mail: info@heidenhain.ru

SE HEIDENHAIN Scandinavia AB

12739 Skärholmen, Sweden

☎ +46 (8) 53193350

E-Mail: sales@heidenhain.se

SG HEIDENHAIN PACIFIC PTE LTD.

Singapore 408593,

☎ +65 6749-3238

E-Mail: info@heidenhain.com.sg

SK Slovakia → CZ

SL Posredništvo HEIDENHAIN

SAŠO HÜBL s.p.

2000 Maribor, Slovenia

☎ +386 (2) 4297216

E-Mail: hubl@siol.net

TH HEIDENHAIN (THAILAND) LTD

Bangkok 10250, Thailand

☎ +66 (2) 398-4147-8

E-Mail: info@heidenhain.co.th

TR T&M Mühendislik San. ve Tic. LTD. ŞTİ.

34738 Erenköy-Istanbul, Turkey

☎ +90 (216) 3022345

E-Mail: info@tmmuhendislik.com.tr

TW HEIDENHAIN Co., Ltd.

Taichung 407, Taiwan

☎ +886 (4) 23588977

E-Mail: info@heidenhain.com.tw

UA Ukraine → RU

US HEIDENHAIN CORPORATION

Schaumburg, IL 60173-5337, USA

☎ +1 (847) 490-1191

E-Mail: info@heidenhain.com

VE Maquinaria Diekmann S.A.

Caracas, 1040-A, Venezuela

☎ +58 (212) 6325410

E-Mail: purchase@diekmann.com.ve

VN AMS Advanced Manufacturing

Solutions Pte Ltd

HCM City, Việt Nam

☎ +84 (8) 9123658 - 8352490

E-Mail: davidgoh@amsvn.com

ZA MAFEMA SALES SERVICES C.C.

Midrand 1685, South Africa

☎ +27 (11) 3144416

E-Mail: mailbox@mafema.co.za

